

Chapter 15

Family and Community Involvement (English).....	159
Family and Community Involvement (Spanish)	160
Section 15.1	161
Section 15.2	167
Section 15.3	173
Section 15.4	179
Technology Connection.....	185

**Chapter
15****Volume and Similar Solids**

Dear Family,

Most families enjoy a movie and popcorn every once in a while. Maybe your family is no different. Have you ever wondered who eats the most popcorn? Maybe all your bowls are the same size, or maybe someone in your family likes to pull the biggest bowl out of the cupboard to fill it with popcorn!

This time, challenge your family to do some math before diving into the popcorn.

What you will need: 2 pieces of paper, tape, popcorn, and a ruler. Make two different cylinders with the two pieces of paper by taping the ends together with minimal overlap.



Measure the heights and the diameters of the cylinders you created. Which cylinder do you think holds more popcorn? Or, do you think they hold the same amount?

Experiment by filling the first cylinder with popcorn. Then carefully transfer the popcorn from the first cylinder to the second cylinder. Do they hold the same amount of popcorn? Which cylinder would you rather have your popcorn in while you watch the movie?

In this chapter, your student will learn how to calculate the volumes of cylinders, cones, and spheres. How is it beneficial to you to know the volume of a cylinder? Think about this as you watch your movie!

**Capítulo
15****Volumen y sólidos similares**

Estimada familia,

La mayoría de las familias disfrutan de ver una película y comer palomitas de maíz de vez en cuando. Puede que tu familia también lo haga. ¿Se han preguntado quién es el que más come palomitas de maíz? Puede que todos tus tazones sean del mismo tamaño, ¡pero a lo mejor alguien saca el tazón más grande de la alacena para llenarlo de palomitas de maíz!

Esta vez, retén a su familia a hacer un cálculo matemático antes de comer palomitas de maíz.

Lo que necesitarán: 2 hojas de papel, cinta pegante, palomitas de maíz, y una regla. Hagan dos cilindros diferentes usando las dos hojas de papel, pegando los bordes y evitando en lo posible que se traslapen.



Midan las alturas y diámetros de los cilindros que hicieron. ¿En cuál cilindro creen que caben más palomitas de maíz? O, ¿creen que en ambos cabe la misma cantidad?

Hagan un experimento rellenando el primer cilindro con palomitas de maíz. Luego transfieran cuidadosamente las palomitas de maíz del primer cilindro al segundo. ¿Cabe la misma cantidad de palomitas de maíz en ambos cilindros? ¿En cuál de los dos cilindros preferirías colocar las palomitas de maíz mientras vez la película?

En este capítulo, su estudiante aprenderá a calcular el volumen de cilindros, conos y esferas. ¿De qué manera les beneficia conocer el volumen de un cilindro?

Activity
15.1**Start Thinking!**

For use before Activity 15.1

Give a real-life example of when knowing the volume of a cylinder would be useful.

Activity
15.1**Warm Up**

For use before Activity 15.1

Simplify.

1. 8^2

2. 14^2

3. 20^2

4. 18^2

5. 25^2

6. 21^2

Lesson
15.1

Start Thinking!

For use before Lesson 15.1

Explain to a partner how to find the volume of water a glass can hold.

Lesson
15.1

Warm Up

For use before Lesson 15.1

Find the volume of the cylinder. Round your answer to the nearest tenth.

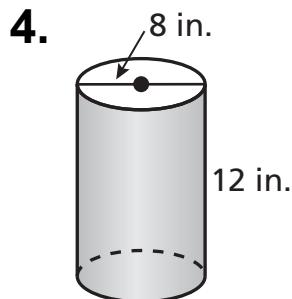
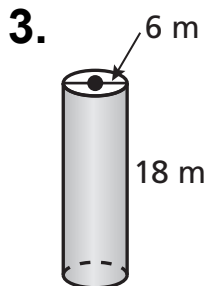
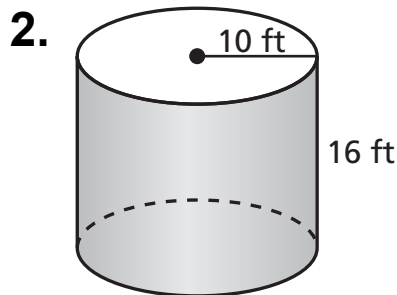
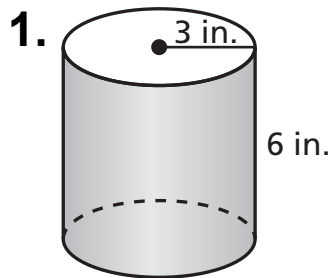

15.1 Practice A

Find the volume of the cylinder. Round your answer to the nearest tenth.

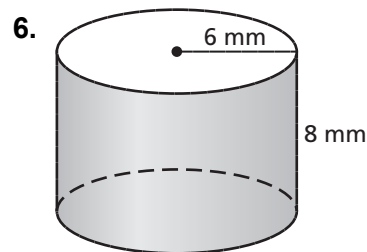
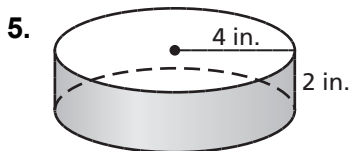
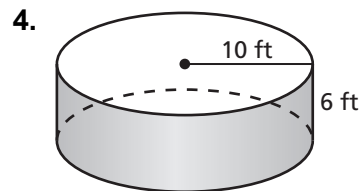
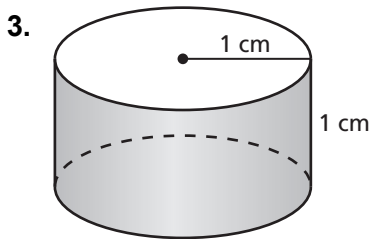
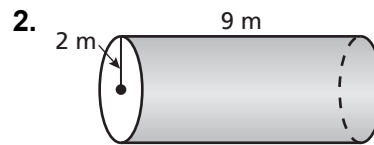
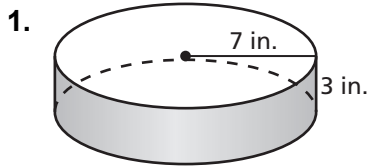

7. A water tank is in the shape of a cylinder with a diameter of 20 feet and a height of 20 feet. The tank is 70% full. About how many gallons of water are in the tank? Round your answer to the nearest whole number. ($1 \text{ ft}^3 \approx 7.5 \text{ gal}$)
8. A cylinder has a surface area of 339 square centimeters and a radius of 6 centimeters. Estimate the volume of the cylinder to the nearest whole number.
9. How does the volume of a cylinder change when its diameter is doubled? Explain.

15.1 Practice B

Find the volume of the cylinder. Round your answer to the nearest tenth.

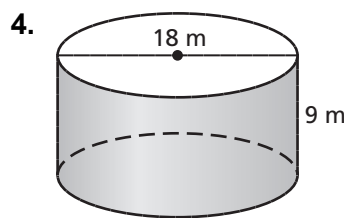
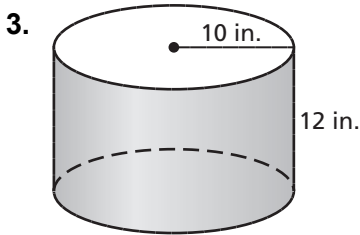
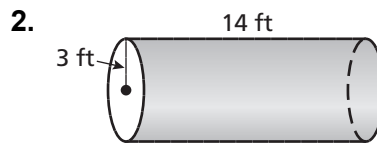
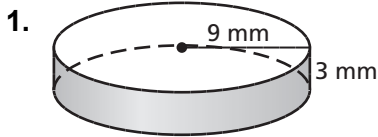

Find the missing dimension of the cylinder. Round your answer to the nearest whole number.

5. Volume = 550 in.^3

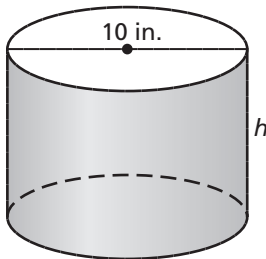

6. Volume = $25,000 \text{ ft}^3$

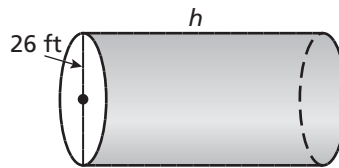

7. Your friend's swimming pool is in the shape of a rectangular prism, with a length of 25 feet, a width of 8 feet, and a height of 5 feet.

- a. What is the volume of your friend's swimming pool?
- b. Your swimming pool is in the shape of a cylinder with a diameter of 16 feet and has the same volume as your friend's pool. What is the height of your pool? Round your answer to the nearest whole number.
- c. While you were on vacation, 6 inches of water evaporated from your pool. About how many gallons of water evaporated from your pool? ($1 \text{ ft}^3 \approx 7.5 \text{ gal}$) Round your answer to the nearest whole number.

15.1 Enrichment and Extension

Camouflage Packaging: Should we be concerned?

The shape and size of a product's packaging is often designed to make it look like you are getting more of the product than you actually are. This "camouflage" packaging may make a product more appealing to the consumer.

1. A deodorant container is approximately a rectangular prism that is 2.5 inches long, 1 inch wide, and 4.7 inches tall. The deodorant inside is only 2.4 inches tall.
 - a. What percent of the container's volume is wasted? Round your answer to the nearest tenth of a percent.
 - b. How many square inches of plastic would be saved with each container by making it the same height as the deodorant?
2. A box containing 10 chocolate-covered cherries is a rectangular prism that is 3.7 inches wide, 7.4 inches long, and 2.5 inches tall. The cherries are approximately spheres with a diameter of 1 inch.
 - a. What percent of the container's volume is wasted? Round your answer to the nearest tenth of a percent. (*Hint:* The formula for the volume of a sphere is $V = \frac{4}{3}\pi r^3$.)
 - b. The company decides to sell the cherries stacked on top of each other in a cylindrical cardboard container. What would be the smallest possible diameter, height, and volume of the container? How much cardboard would they save by using this packaging design? Explain.
3. What are some environmental consequences of camouflage packaging? Also, describe how camouflage packaging affects shipping and transportation and the effect that has on the environment.
4. Find your own example of camouflage packaging. Write a persuasive letter to the company supporting packaging designs that are less wasteful. Be sure to include the following things:
 - the percent of the current container's volume that is wasted space
 - a design for packaging that will have less wasted space and take less material to make
 - how much packaging material would be saved with your design
 - some of the environmental consequences from Exercise 3

15.1 Puzzle Time

Did You Hear About...

A	B	C	D	E	F
G	H	I	J	K	L
M	N				

Complete each exercise. Find the answer in the answer column. Write the word under the answer in the box containing the exercise letter.

63.6 cm ³ BECAUSE	Find the volume of the cylinder. Round your answer to the nearest tenth.	7 cm DECK
356.9 in. ³ SO	A. $r = 12$ in.; $h = 4$ in. B. $r = 6$ ft; $h = 7$ ft	754.0 ft ³ THE
128.4 cm SEA	C. $r = 3$ cm; $h = 13$ cm D. $r = 9$ m; $h = 11$ m	3015.9 ft ³ PLAY
791.7 ft ³ SAILORS	E. $r = 8$ ft; $h = 15$ ft F. $d = 10$ cm; $h = 7$ cm	1 in. STANDING
88.9 ft SHIP	G. $d = 3$ cm; $h = 9$ cm H. $d = 8$ ft; $h = 15$ ft	65.7 ft ³ SITTING
549.8 cm ³ CARDS	I. $d = 14$ m; $h = 15$ m J. $d = 6$ ft; $h = 21$ ft	521.6 in. BOAT
22 in. THE	Find the missing dimensions of the cylinder. Round your answer to the nearest whole number.	2309.1 m ³ CAPTAIN
2799.2 m ³ COULDN'T	K. An official NHL hockey puck is shaped like a cylinder with a diameter of 3 inches and a volume of 7.1 cubic inches. What is the height of the hockey puck?	99.8 in. ³ WASN'T
435.7 m ³ HAD	L. A water trampoline is shaped like a cylinder with a diameter of 11 feet and a volume of 190.1 cubic feet. What is the height of the trampoline?	1809.6 in. ³ THE
593.8 ft ³ WAS	M. A rolled-up sleeping bag is shaped like a cylinder with a radius of 5 inches and a volume of 1727.9 cubic inches. What is the height of the rolled-up sleeping bag?	367.6 cm ³ WHO
2 ft ON	N. A sports bottle is shaped like a cylinder with a height of 19 centimeters and a volume of 731.2 cubic centimeters. What is the diameter of the sports bottle?	131.4 in. ARE

Activity
15.2

Start Thinking!

For use before Activity 15.2

Review with a partner the formulas for finding the area of the following figures:

square

rectangle

triangle

circle

Activity
15.2

Warm Up

For use before Activity 15.2

Find the area. Round your answer to the nearest tenth.

1.

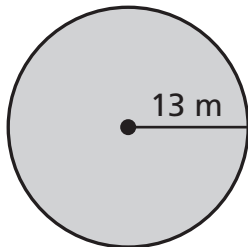

2.

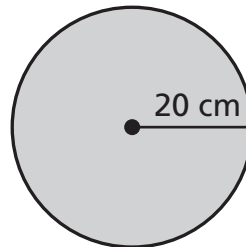

3.

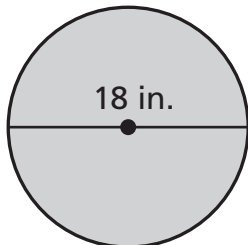

4.

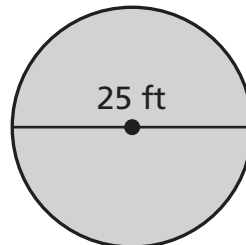

Lesson
15.2

Start Thinking!

For use before Lesson 15.2

Explain which sugar cone can hold more ice cream:

Sugar cone 1: radius 3 cm; height 14 cm

Sugar cone 2: diameter 7 cm; height 13 cm

Lesson
15.2

Warm Up

For use before Lesson 15.2

Find the volume of the cone. Round your answer to the nearest tenth.

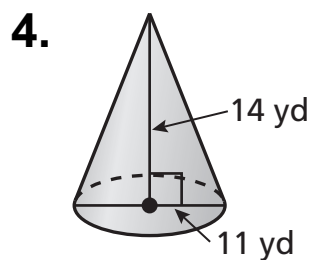
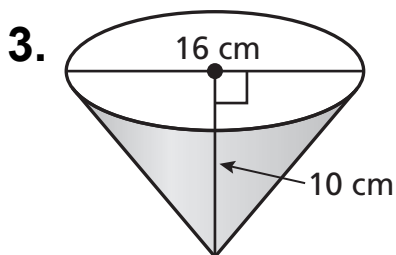
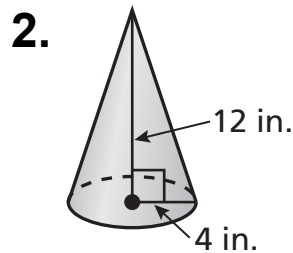
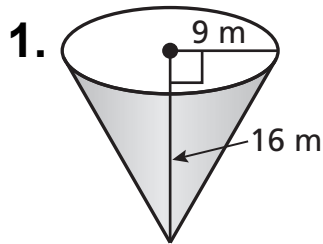

15.2 Practice A

Find the volume of the cone. Round your answer to the nearest tenth.

1.

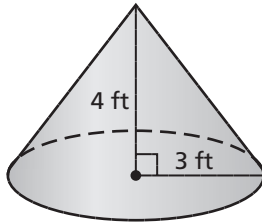

2.

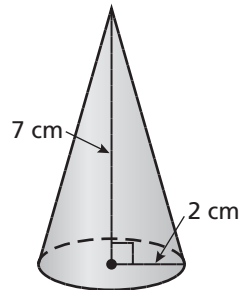

3.

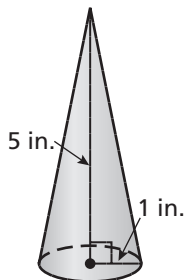

4.

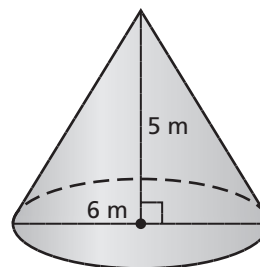

5.

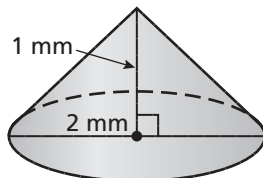

6.

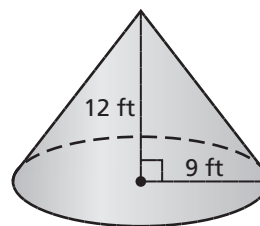

7. The volume of a cylinder is 24π cubic feet. What is the volume of a cone having the same base and same height?
8. A funnel is in the shape of a cone with a radius of 4 inches and a height of 10 inches.
- Find the volume of the funnel. Round your answer to the nearest tenth.
 - The funnel is filled with oil. How many quarts of oil are in the funnel? ($1 \text{ qt} \approx 58 \text{ in.}^3$) Round your answer to the nearest tenth.

15.2 Practice B

Find the volume of the cone. Round your answer to the nearest tenth.

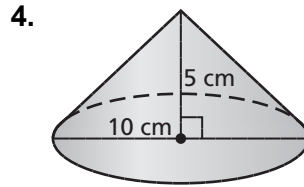
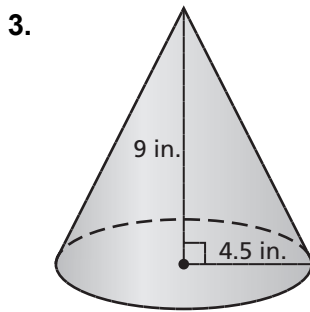
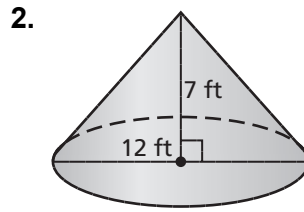
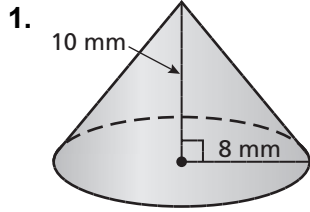

Find the missing dimension of the cone. Round your answer to the nearest tenth.

5. Volume = 100 in.^3

6. Volume = 13.4 m^3

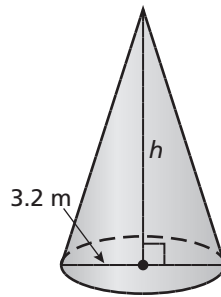
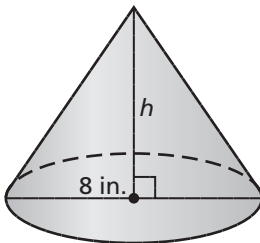

7. A paper cup is in the shape of a cone, with a diameter of 2 centimeters and a height of 5 centimeters.

- What is the volume of the paper cup?
- Water is running into the cup at a rate of 1.5 cubic centimeters per second. How long does it take for the cup to fill with water? Round your answer to the nearest tenth.

8. Cone A has the same radius but half the height of Cone B. What is the ratio of the volume of Cone A to the volume of Cone B?

15.2 Enrichment and Extension

I Scream...You Scream...We all Scream for Ice Cream...Cones!?!

Have you ever been at an ice cream shop and been faced with the question, “Would you like that in a cake cone or sugar cone?” You may or may not have a taste preference, but how do you know which one holds more?

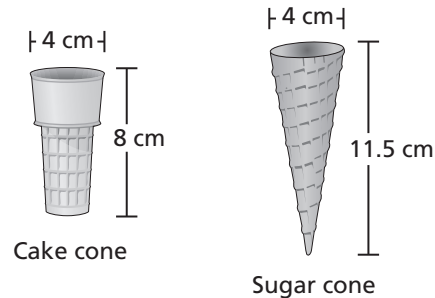

- Predict which of the two ice cream cones will hold more. Explain your reasoning.
- The cake cone is approximately in the shape of a cylinder. Calculate the volume of both ice cream cones. Round your answers to the nearest tenth.
- Was your prediction correct? Explain.
- You order a medium soft serve frozen yogurt. Does it matter what kind of cone you choose? Will you get more ice cream if you choose the cake cone? What if you order two scoops of hard ice cream instead? Explain your reasoning.
- The diameter of the sugar cone stays the same. How tall would the sugar cone have to be in order to have the same volume as the cake cone?
- The box for the sugar cones has a recipe for a snack. It says that 1 chopped banana mixed with 1 cup chocolate pudding and $\frac{1}{4}$ cup chopped peanuts will fill 5 sugar cones. About how many batches of this recipe would it take to fill 5 of the cake cones pictured above?
- The cake cone above is jumbo size. The box says they hold 50% more.
 - How much do the regular size cake cones hold? Do the regular size cake cones still hold more than the sugar cones?
 - The regular size cake cones have the same diameter as the jumbo size. How tall are they?

15.2 Puzzle Time

Who Took Tiny Pieces Of Mail Across Country Over A Hundred Years Ago?

Write the letter of each answer in the box containing the exercise number.

Find the volume of the cone. Round your answer to the nearest tenth.

- 1. $r = 3$ in.; $h = 5$ in.
- 2. $r = 4$ cm; $h = 6$ cm
- 3. $r = 5$ ft; $h = 12$ ft
- 4. $r = 3$ m; $h = 13$ m
- 5. $r = 7$ ft; $h = 7$ ft
- 6. $d = 10$ cm; $h = 6$ cm
- 7. $d = 14$ m; $h = 5$ m
- 8. $d = 8$ in.; $h = 7$ in.
- 9. $d = 12$ ft; $h = 9$ ft
- 10. $d = 15$ in.; $h = 8$ in.

Find the missing dimension of the cone. Round your answer to the nearest tenth.

- 11. A sorcerer’s hat is shaped like a cone with a diameter of 8 inches and a volume of 301.6 cubic inches. What is the height of the sorcerer’s hat?
- 12. A pine tree is shaped like a cone with a radius of 8 feet and a volume of 3887.2 cubic feet. What is the height of the pine tree?
- 13. A waterspout forms in the shape of a cone with a height of 35 meters and a volume of 229.1 cubic meters. What is the diameter of the waterspout?
- 14. Sand poured from a beach pail forms a cone with a height of 32 centimeters and a volume of 3351.0 cubic centimeters. What is the radius of the sand poured from a beach pail in the shape of a cone?

Answers

- P. 256.6 m^3
- E. 471.2 in.^3
- S. 122.5 m^3
- R. 18 in.
- H. 359.2 ft^3
- X. 5 m
- E. 100.5 cm^3
- T. 314.2 ft^3
- P. 58 ft
- Y. 157.1 cm^3
- E. 117.3 in.^3
- N. 47.1 in.^3
- U. 10 cm
- S. 339.3 ft^3

3	5	8		12	14	1	6		10	13	7	11	2	9	4
---	---	---	--	----	----	---	---	--	----	----	---	----	---	---	---

Activity
15.3

Start Thinking!

For use before Activity 15.3

Review with a partner the formulas for the volumes of cylinders and cones.

How are the formulas similar? How are they different?

Activity
15.3

Warm Up

For use before Activity 15.3

Find the area of the circle. Round your answer to the nearest tenth.

1.

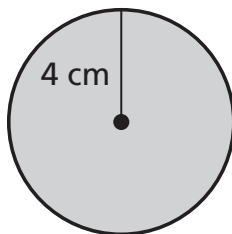

2.

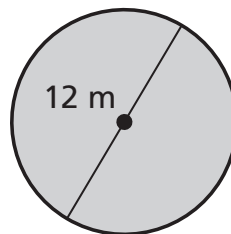

3.

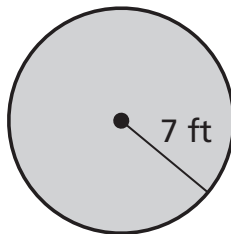

4.

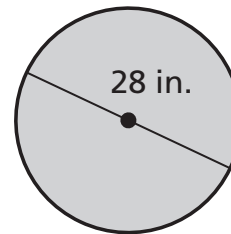

Lesson
15.3

Start Thinking!

For use before Lesson 15.3

Give a real-life example of how finding the volume of a sphere may be useful.

Lesson
15.3

Warm Up

For use before Lesson 15.3

Find the volume of the sphere. Round your answer to the nearest tenth.

1.

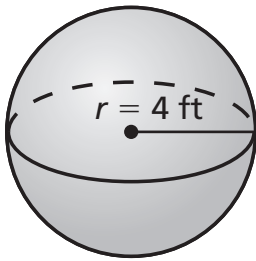

2.

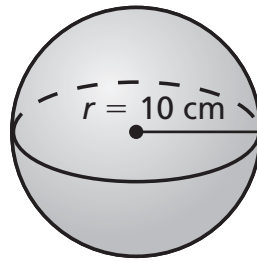

3.

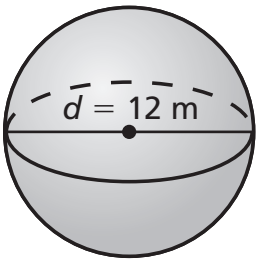

4.

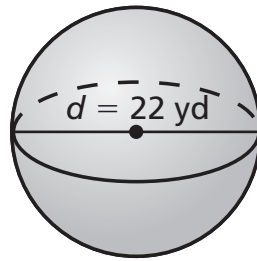

15.3 Practice A

Find the volume of the sphere. Round your answer to the nearest tenth.

1.

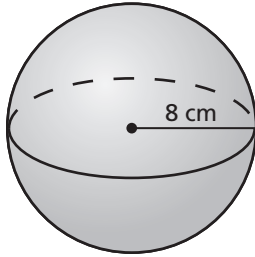

2.

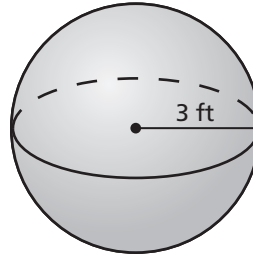

3.

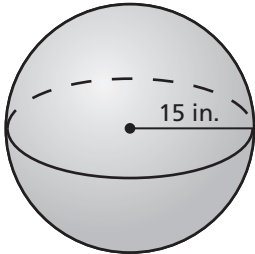

4.

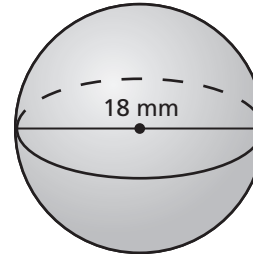

Find the radius of the sphere with the given volume.

5. Volume = 288π in.³

6. Volume = 562.5π cm³

7. A fishing bobber has a radius of 0.5 inch. Find the volume of the fishing bobber. Round your answer to the nearest tenth.

Find the volume of the composite solid. Round your answer to the nearest tenth.

8.

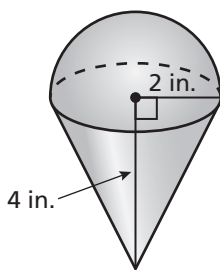

9.

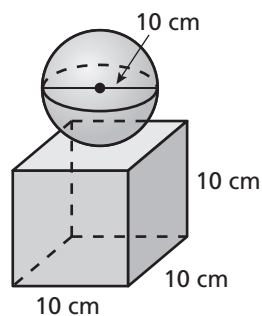

15.3 Practice B

Find the volume of the sphere. Round your answer to the nearest tenth.

1.

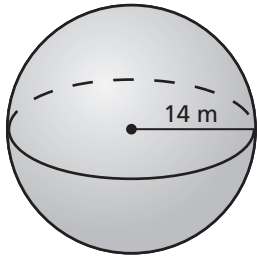

2.

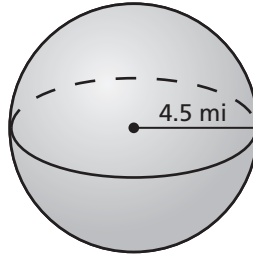

3.

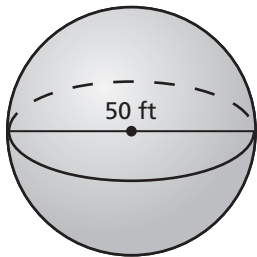

4.

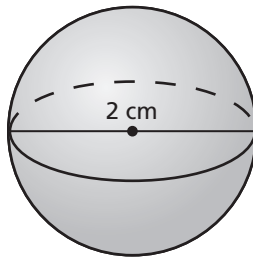

Find the radius of the sphere with the given volume.

5. Volume = $2304\pi \text{ yd}^3$

6. Volume = $1543.5\pi \text{ mm}^3$

7. A spherical cabinet knob has a radius of 1.5 inches. Find the volume of the cabinet knob. Round your answer to the nearest tenth.

Find the volume of the composite solid. Round your answer to the nearest tenth.

8.

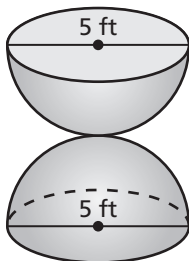

9.

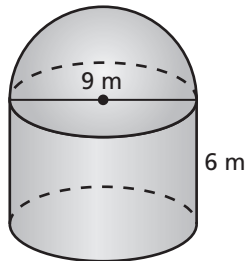

15.3 Enrichment and Extension

The Dodgeball Advantage

Dodgeball is a popular game among students. The object of the game is to pick up a rubber ball and throw it at members of the other team. If you hit them, they are out. But if a member of the other team catches the ball, you're out!

Frequently, games of dodgeball are played with multiple balls of different sizes. Which size is best for you?

1. Open your throwing hand (usually your right hand if you are right-handed, left hand if you are left-handed) and use a ruler to measure the distance from the tip of your thumb to the tip of your pinky finger. Record the measurement.
2. The circumference of a ball is the distance around the widest part of the ball. Find as many different-sized balls as you can, and measure the circumference of each. If you do not have a measuring tape you can get an inexact measurement with a yardstick by marking the ball and rolling it alongside the yardstick until you have made one full revolution. Record these measurements.
3. In order to grip a ball and be able to throw it with maximum velocity and accuracy, the ratio of your hand size to ball circumference must be greater than about $\frac{1}{3}$. Use this ratio to determine which of the balls meet this criteria.
4. Multiply your hand size by 3. This is about the maximum circumference a ball can have and still be thrown with the greatest velocity and accuracy. Record this measurement.
5. How do your answers to Exercises 2–4 help you during a game of dodgeball in which there are different-sized balls?
6. What does it mean if the ratio from Exercise 3 is greater than 1?
7. Most balls used for dodgeball are rubber and can be squeezed. Use the information from Exercise 3 to explain why this helps you grip a larger ball.

15.3 Puzzle Time

What Is It That Never Asks Questions But Often Has To Be Answered?

Write the letter of each answer in the box containing the exercise number.

Find the volume of the sphere with the given radius or diameter.
Round your answer to the nearest tenth.

- 1. $r = 16$ in.
- 2. $r = 9$ in.
- 3. $r = 8$ in.
- 4. $r = 10$ in.
- 5. $d = 26$ in.
- 6. $d = 22$ in.

Find the radius of the sphere with the given volume.

- 7. Volume = 2304π in.³
- 8. Volume = 562.5π in.³
- 9. Volume = $18,432\pi$ in.³
- 10. Volume = 1543.5π in.³
- 11. A snow globe consists of a pedestal in the shape of a cube with a sphere mounted on top of the pedestal. The pedestal has an edge length of 4 inches and the sphere has a diameter of 3 inches. What is the volume of the snow globe rounded to the nearest cubic inch?

Answers

- E. 3053.6 in.³
- L. 7.5 in.
- D. 78 in.³
- H. 9208.8 in.³
- O. 24 in.
- E. 17,157.3 in.³
- R. 5575.3 in.³
- O. 2144.7 in.³
- T. 12 in.
- B. 10.5 in.
- L. 4188.8 in.³

7	5	2		11	9	3	6	10	1	8	4
---	---	---	--	----	---	---	---	----	---	---	---

Activity
15.4**Start Thinking!**
For use before Activity 15.4

Explain how a juice factory would use volume.

Activity
15.4**Warm Up**
For use before Activity 15.4

Tell whether the ratios are equivalent.

1. $\frac{35}{20}, \frac{7}{4}$

2. $\frac{3}{8}, \frac{32}{12}$

3. $\frac{4}{8}, \frac{20}{24}$

4. $\frac{9}{2}, \frac{27}{6}$

5. $\frac{14}{18}, \frac{12}{21}$

6. $\frac{14}{20}, \frac{21}{30}$

Explain to a partner how to determine if two figures are similar.

1. All the dimensions of a cube increase by a factor of $\frac{5}{4}$.
 - a. How many times greater is the surface area? Explain.
 - b. How many times greater is the volume? Explain.

15.4

Practice A

Determine whether the solids are similar.

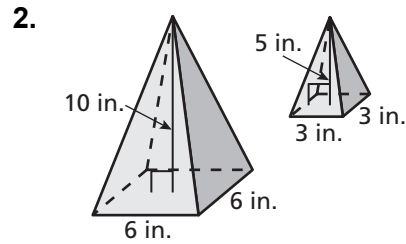
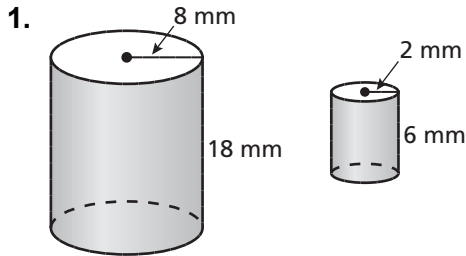

The solids are similar. Find the missing dimension(s).

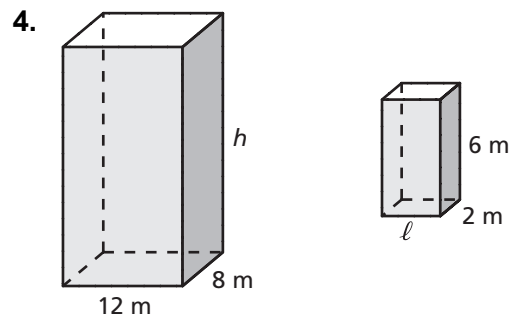
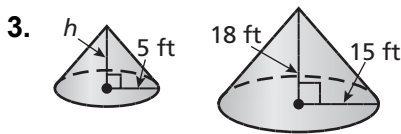

The solids are similar. Find the surface area S or the volume V of the larger solid. Round your answer to the nearest tenth.

5. Volume = 250 mm^3

6. Surface Area = 130 ft^2

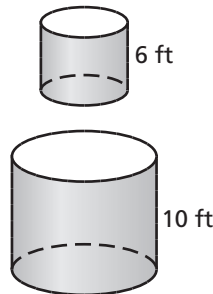
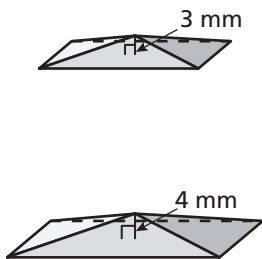

7. The ratio of the corresponding linear measures of two similar cans of cat food is 4 : 3.
- The larger can has a surface area of 100 square inches. Find the surface area of the smaller can. Round your answer to the nearest tenth.
 - The larger can has a volume of 150 cubic inches. Find the volume of the smaller can. Round your answer to the nearest tenth.

15.4 Practice B

The solids are similar. Find the missing dimension(s).

1.

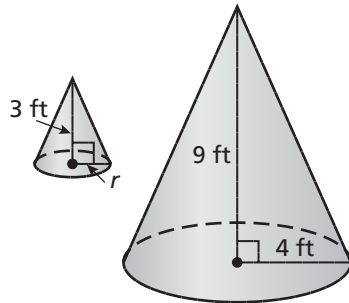

2.

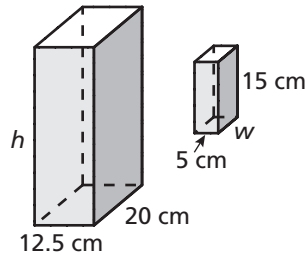

The solids are similar. Find the surface area S or the volume V of the smaller solid. Round your answers to the nearest tenth.

3. Surface Area = 294.7 m^2

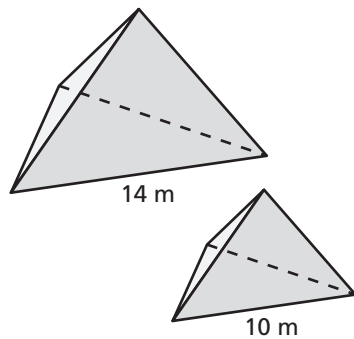

4. Volume = 1500 ft^3

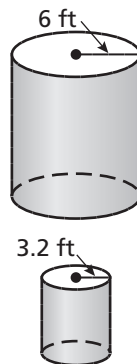

5. The ratio of the corresponding linear measures of two similar buckets of popcorn is 2 to 5. The larger bucket has a volume of 390 cubic inches. Find the volume of the smaller bucket. Round your answer to the nearest tenth.

6. A box of 60 tissues has a length of 11 centimeters, a width of 10.5 centimeters, and a height of 13.5 centimeters.

a. Find the volume of the box of tissues. Round your answer to the nearest tenth.

b. A similar box contains 100 tissues. The ratio of the corresponding linear measures of the two boxes is 3 : 5. Find the volume of the larger box. Round your answer to the nearest tenth.

c. Find the dimensions of the larger box. Round your answers to the nearest tenth.

15.4 Enrichment and Extension

Logical Measuring

Example: You are making pasta out of a box that contains all the ingredients except for the water. You have to add exactly 2 cups of water. However, all you can find are two irregularly shaped containers. One holds 4 cups exactly, and the other holds 5 cups exactly. Neither one is marked, nor can they be marked. How can you use them to measure exactly 2 cups of water?

- Step 1** Fill the 5-cup container. Pour it into the 4-cup container until the 4-cup container is full and there is exactly one cup left in the 5-cup container.
- Step 2** Empty the 4-cup container. Pour the one cup from the 5-cup container into the 4-cup container.
- Step 3** Refill the 5-cup container. Pour it into the 4-cup container until it is full. Because there is already one cup in the 4-cup container, there are exactly two cups left in the 5-cup container.

For each situation, the containers are irregular shapes and cannot be marked. Unless otherwise stated, you have unlimited access to more water. Answer each logic puzzle by giving the steps you would take. Try to do each with the least number of steps possible.

1. You have a 4-cup container and a 3-cup container. How can you use them to measure exactly 2 cups of water?
2. You have a 4-cup container and a 9-cup container. How can you use them to measure exactly 6 cups of water?
3. You have a 4-cup container and a 7-cup container. How can you use them to measure exactly 5 cups of water?
4. You have a 5-cup container and a 3-cup container. How can you use them to measure exactly 4 cups of water? There are two solutions to this one. See if you can find them both. Which one has less wasted water?
5. You have a 3-cup container, a 5-cup container, and an 8-cup container. The 8-cup container is exactly full with sugar, but the other two are empty. You want to split it evenly with a friend so you can both make the same recipe, which calls for 4 cups of sugar. Neither of you has any more sugar. How can you make it so that two of the containers have exactly 4 cups of sugar?



15.4 Puzzle Time

What Kind Of Seafood Do Weight Lifters Like Best?

Write the letter of each answer in the box containing the exercise number.

The solids are similar solids. Find the missing dimension.

- Cylinder A: $r = 6$ in.; $h = 15$ in. Cylinder B: $r = 8$ in.; $h =$?
 R. 18 in. S. 20 in. T. 24 in.
- Cone X: $h = 12$ ft; $r = 9$ ft Cone Y: $h = 28$ ft; $r =$?
 E. 21 ft F. 27 ft G. 36 ft
- Pyramid F: $\ell = 7$ cm; $h = 10$ cm Pyramid G: $\ell = 4.2$ cm; $h =$?
 Q. 4 cm R. 5 cm S. 6 cm

The solids are similar. Find the missing surface area S or volume V .

- Prism M: $w = 4$ mm; $S = 148$ mm² Prism N: $w = 6$ mm; $S =$?
 J. 254 mm² K. 278 mm² L. 333 mm²
- Cone Y: $r = 3$ yd; $S = 36\pi$ yd² Cone Z: $r = 7$ yd; $S =$?
 R. 182π yd² S. 196π yd² T. 204π yd²
- Cylinder J: $h = 13$ m; $V = 1300\pi$ m³ Cylinder K: $h = 19.5$ m; $V =$?
 U. 4387.5π m³ V. 4597π m³ W. 4775.5π m³
- Pyramid C: $h = 15$ in.; $V = 240$ in.³ Pyramid D: $h = 18$ in.; $V =$?
 K. 396.14 in.³ L. 408.81 in.³ M. 414.72 in.³

7	6	3	5	2	4	1
---	---	---	---	---	---	---

Chapter
15
Technology Connection

For use after Section 15.3

Finding Cube Roots

Because of its frequent use, even most simple calculators have a square root key, $\sqrt{\square}$. To find a root higher than a square root (cube root, fourth root, etc.), scientific calculators contain a “principal n th root” key, $\sqrt[x]{\square}$ or $\sqrt[x]{y}$, where x (the *index* of the root) indicates the type of root to be found.

EXAMPLE Find the cube root of 100.

SOLUTION

The cube root of 100 can be written as $\sqrt[3]{100}$. On your calculator, enter 3 $\boxed{2\text{nd}}$ $\boxed{\sqrt[x]{\square}}$ 100 $\boxed{=}$. The answer is approximately 4.642.

EXAMPLE A standard size 5 soccer ball has a volume of 333 cubic inches. What is the diameter of the ball to the nearest tenth of an inch? Let $\pi = 3.14$.

SOLUTION

Step 1 Substitute 333 into the formula for the volume of a sphere to get $333 = \frac{4}{3}\pi r^3$.

Step 2 Solve the equation for r^3 and let $\pi = 3.14$ to find $r^3 \approx 79.54$.

Step 3 Solve for r by taking the cube root of both sides of the equation. On your calculator, enter 3 $\boxed{2\text{nd}}$ $\boxed{\sqrt[x]{\square}}$ 79.54 $\boxed{=}$. Your display should show approximately 4.3. This is the radius of the ball.

Step 4 Finally, double the radius to calculate the diameter of the ball. Your solution is about 8.6 inches.

Use a scientific or graphing calculator to find the roots below.

1. $\sqrt[3]{512}$

2. $\sqrt[3]{-421.875}$

3. $\sqrt[4]{20,736}$

4. The volume of a men’s basketball is about 434 cubic inches. If the volume of a women’s basketball is 43 cubic inches less than a men’s ball, what is the difference in diameters of the two sizes of basketballs? Let $\pi = 3.14$. Round your answer to the nearest tenth.