

# Chapter 3

Family and Community Involvement (English).....	75
Family and Community Involvement (Spanish) .....	76
Section 3.1 .....	77
Section 3.2 .....	83
Section 3.3 .....	89
Section 3.4 .....	95
Technology Connection.....	101

**Chapter  
3****Angles and Triangles**

Dear Family,

Take a look at the structures in your neighborhood. What shapes do you see over and over again? Triangles can be seen everywhere. Peaked roofs are made with triangular sections; umbrellas use triangular wedges; bridges use triangular shapes to span great distances.

The triangle is used in many structures because it is a stable shape. There is only one way to form a polygon with three given segments and this makes the shape strong. A square can shift into a parallelogram. A circle can be deformed into an oval shape without changing the perimeter. But a triangle retains its shape.

You may want to use toothpicks and gum drops to create a triangle, square, and rectangle. Test the strength of each shape to reinforce that the triangle provides the most support.

Triangles can be used to form the sides of pyramids or the ends of prisms, making them popular for building roofs. More complicated patterns can be used to approximate nearly any shape. A geodesic dome uses triangles to create a sphere-like shape. Try this with your student. Choose a structure, such as your home or a nearby building or bridge.

- What types of triangles are used in the structure? Are they all similar, or are different triangles used?
- What types of angles are used? Are they acute (less than 90 degrees), right (equal to 90 degrees), or obtuse (greater than 90 degrees)? Why do you think those angles are chosen?
- Are there triangular parts inside of the structure? Try looking at the trusses in an attic or under a bridge. Why do you think the shapes you see were chosen?

You may want to build a model of your structure using toothpicks and gum drops or other similar materials.

Have fun looking at your structure from "every angle"!

**Capítulo**  
**3****Ángulos y triángulos**

Estimada Familia:

Observe las estructuras en su barrio. ¿Qué formas observa una y otra vez? Los triángulos se pueden ver por todas partes. Los techos puntiagudos están compuestos de secciones triangulares; los paraguas utilizan pedazos triangulares, los puentes usan formas triangulares para cubrir grandes distancias.

El triángulo se utiliza en muchas estructuras porque es una forma estable. Sólo hay un modo para formar un polígono con tres segmentos dados y esto hace que la forma sea fuerte. Un cuadrado puede convertirse en un paralelogramo. Un círculo puede deformarse en una forma ovalada sin cambiar el perímetro. Pero un triángulo conserva su forma.

Puede querer usar palitos de dientes y gomitas dulces para crear un triángulo, un cuadrado y un rectángulo. Ponga a prueba la resistencia de cada forma para comprobar que el triángulo brinda el mayor soporte.

Los triángulos pueden ser usados para formar los lados de las pirámides o las terminaciones de un prisma, haciéndolos populares para construir techos. Los patrones más complicados pueden ser usados para aproximarse casi a cualquier forma. Un domo geodésico utiliza un triángulo para crear la forma de una esfera. Intente lo siguiente con su estudiante. Escojan una estructura, como su casa o un edificio o puente cercano.

- ¿Qué tipos de triángulos son usados en esta estructura? ¿Son todos similares o se utilizan distintos tipos de triángulos?
- ¿Qué clase de ángulos se utilizan? ¿Son agudos (menores de 90 grados), rectos (iguales a 90 grados) u obtusos (mayores de 90 grados)? ¿Por qué creen que se escogen estos ángulos?
- ¿Hay partes triangulares dentro de la estructura? Observen las estructuras en un ático o bajo un puente. ¿Por qué creen que las formas que observan fueron escogidas?

Querrán construir un modelo de sus estructuras usando palitos de dientes, gomitas dulces o materiales similares.

¡Diviértanse observando su estructura desde "todos los ángulos"!

**Activity**  
**3.1****Start Thinking!**

For use before Activity 3.1

Give some examples of parallel lines in your classroom.

**Activity**  
**3.1****Warm Up**

For use before Activity 3.1

**Solve the proportion.**

1.  $\frac{16}{3} = \frac{x}{9}$

2.  $\frac{2}{5} = \frac{5}{x}$

3.  $\frac{15}{12} = \frac{x}{8}$

4.  $\frac{x}{2} = \frac{11}{4}$

5.  $\frac{100}{x} = \frac{25}{8}$

6.  $\frac{x}{5} = \frac{3}{8}$

If you know the measure of one of the angles formed by two parallel lines and a transversal, can you find the measures of all the other angles without using a protractor? Why or why not?

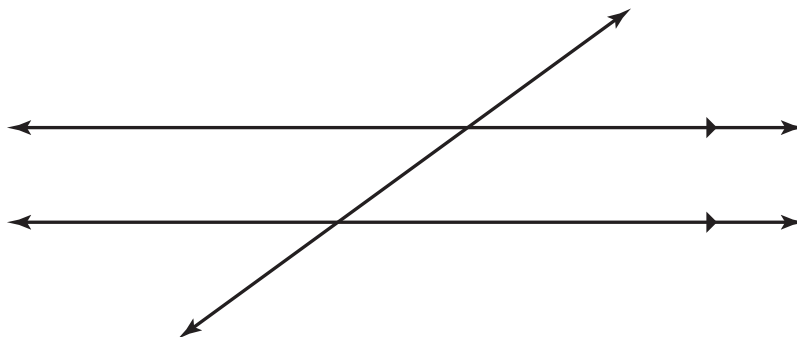

**Use the figure.**

1. Identify the parallel lines.
2. Identify the transversal.
3. How many angles are formed by the transversal?
4. Which of the angles are congruent?

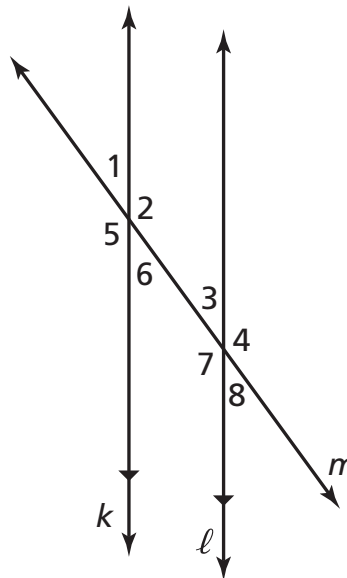

# 3.1

## Practice A

Use the figure to find the measures of the numbered angles.

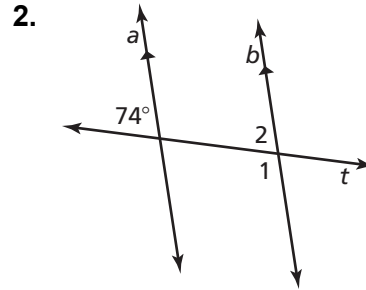
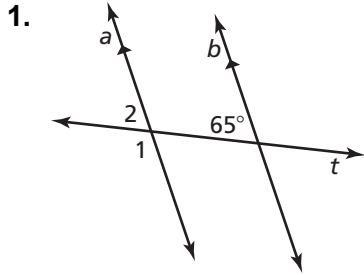

Use the figure to find the measures of the numbered angles. Explain your reasoning.

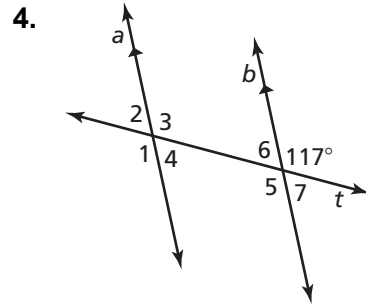
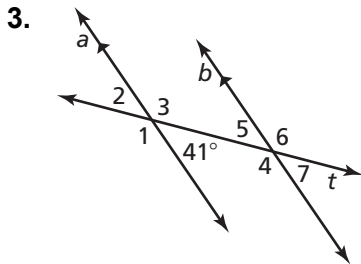

Complete the statement. Explain your reasoning.

5. If the measure of  $\angle 1 = 160^\circ$ , then the measure of  $\angle 5 = \underline{\quad ? \quad}$ .
6. If the measure of  $\angle 6 = 37^\circ$ , then the measure of  $\angle 4 = \underline{\quad ? \quad}$ .
7. If the measure of  $\angle 8 = 82^\circ$ , then the measure of  $\angle 3 = \underline{\quad ? \quad}$ .
8. If the measure of  $\angle 4 = 60^\circ$ , then the measure of  $\angle 5 = \underline{\quad ? \quad}$ .

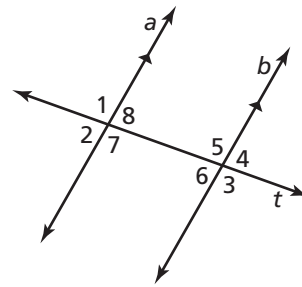

Correct the following statements about the numbered angles by replacing the underlined words with the correct words.

9.  $\angle 2$  is congruent to  $\angle 4$ .  $\angle 4$  is congruent to  $\angle 8$ .  
So,  $\angle 2$  is supplementary to  $\angle 8$ .
10.  $\angle 6$  is congruent to  $\angle 3$ .  $\angle 3$  is congruent to  $\angle 1$ .  
So,  $\angle 6$  is congruent to  $\angle 1$ .

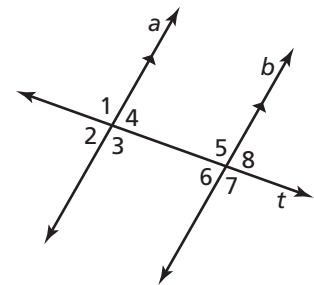

# 3.1

## Practice B

Use the figure to find the measures of the numbered angles. Explain your reasoning.

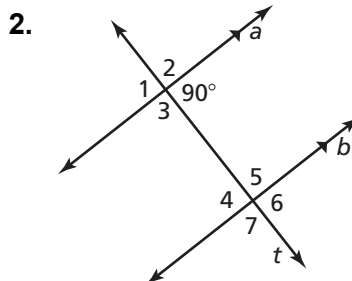
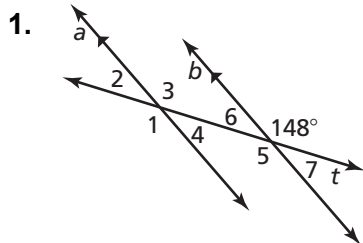

Complete the statement. Explain your reasoning.

3. If the measure of  $\angle 1 = 130^\circ$ , then the measure of  $\angle 8 = \underline{\quad ? \quad}$ .
4. If the measure of  $\angle 5 = 53^\circ$ , then the measure of  $\angle 3 = \underline{\quad ? \quad}$ .
5. If the measure of  $\angle 7 = 71^\circ$ , then the measure of  $\angle 3 = \underline{\quad ? \quad}$ .
6. If the measure of  $\angle 4 = 65^\circ$ , then the measure of  $\angle 6 = \underline{\quad ? \quad}$ .

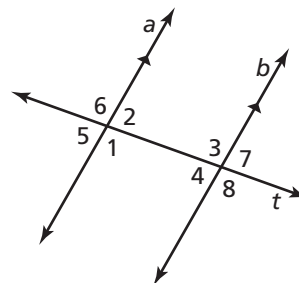

Using the diagram for angle placement only (the measurement of the angles may change), indicate if the following statements are *always*, *sometimes*, or *never* true. Explain.

7.  $\angle 1$  is congruent to  $\angle 3$ .
8.  $\angle 6$  is supplementary to  $\angle 8$ .
9.  $\angle 2$  is complementary to  $\angle 1$ .
10.  $\angle 8$  and  $\angle 5$  are vertical angles.
11.  $\angle 2$  is congruent to  $\angle 8$ .

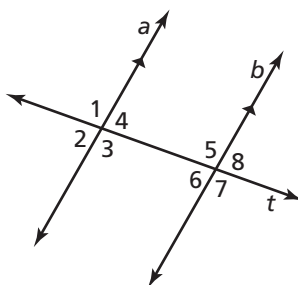

12. If a transversal intersects two parallel lines, is it possible for all of the angles formed to be acute angles? Explain.

## 3.1 Enrichment and Extension

### Telescopes

The most basic design for a telescope is a long tube with a lens at each end. The larger lens, called the objective lens, focuses a distant image to a point inside the tube, called the focal point. The smaller lens, called the eyepiece, has the same focal point and works like a magnifying glass. The result is that your eye sees an enlarged view of the image from the objective lens.

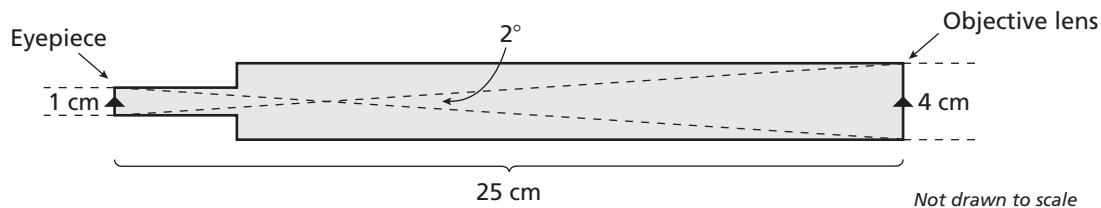

1. A lens and its focal point form an isosceles triangle. What are the angle measures of the triangle formed by the objective lens and the focal point?
2. Does the triangle formed by the eyepiece and the focal point have the same angle measures? Explain your reasoning.
3. What is the ratio of the diameters of the objective lens to the eyepiece?
4. The distance from a lens to its focal point is called the focal length. The ratio of the focal lengths is the same as the ratio of the diameters. Find the focal length (in centimeters) of each lens.
5. The focal length of the eyepiece determines the magnification of the telescope. The number of times  $m$  an image is magnified is represented by the equation  $m = \frac{250}{f}$ , where  $f$  is the focal length (in millimeters). How many times is the image magnified in the telescope above?
6. If the length of the telescope increased, would the magnification of the telescope increase or decrease? Explain.



# 3.1 Puzzle Time

## Why Did The Rabbit Wear A Shower Cap?

A	B	C	D	E	F
G	H				

Complete each exercise. Find the answer in the answer column. Write the word under the answer in the box containing the exercise letter.

147 HARE
44 WANT
129 ITS
c IT

Use the figure to answer the questions.

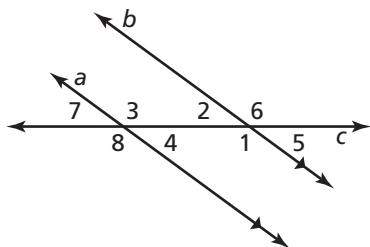

a, b DIDN'T
51 GET
112 WET
136 TO

- A. Identify the transversal.
- B. Identify the parallel lines.
- C. If the measure of  $\angle 1 = 136^\circ$ , then the measure of  $\angle 2 = \underline{\hspace{2cm}}^\circ$ .
- D. If the measure of  $\angle 4 = 44^\circ$ , then the measure of  $\angle 8 = \underline{\hspace{2cm}}^\circ$ .
- E. If the measure of  $\angle 8 = 129^\circ$ , then the measure of  $\angle 4 = \underline{\hspace{2cm}}^\circ$ .
- F. If the measure of  $\angle 3 = 129^\circ$ , then the measure of  $\angle 1 = \underline{\hspace{2cm}}^\circ$ .

Find the value of  $x$ .

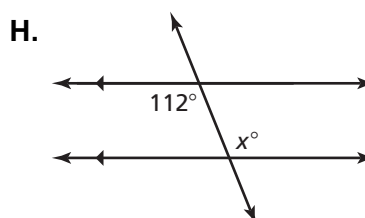
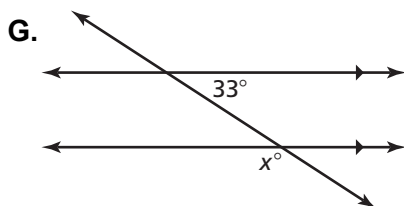

**Activity**  
**3.2**

**Start Thinking!**  
For use before Activity 3.2

Describe some real-life triangles. What kind of triangles are they?

**Activity**  
**3.2**

**Warm Up**  
For use before Activity 3.2

**Classify the angle as *acute*, *right*, *obtuse*, or *straight*.**

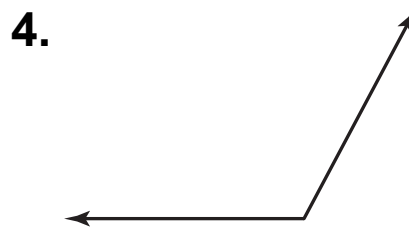
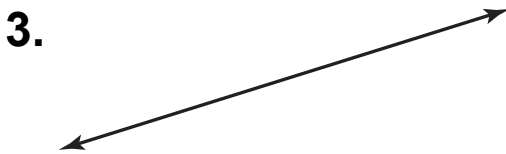
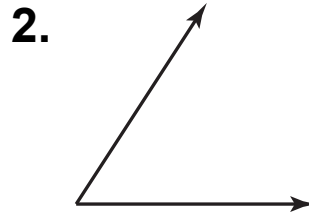
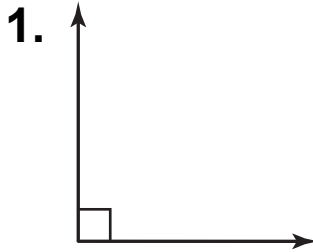

**Lesson**  
**3.2**

**Start Thinking!**

For use before Lesson 3.2

Give a real-life example of when it is important to know the angle measures of a triangle.

**Lesson**  
**3.2**

**Warm Up**

For use before Lesson 3.2

Find the measures of the interior angles.

1.

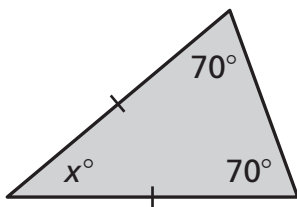

2.

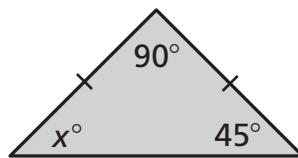

3.

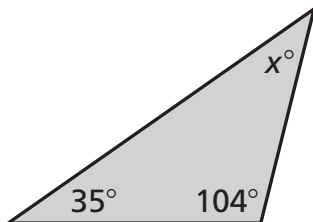

4.

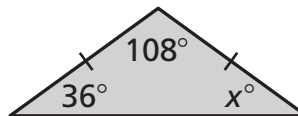

5.

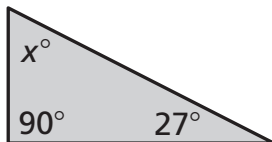

6.

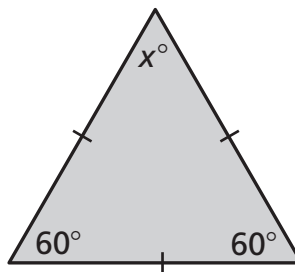

# 3.2

## Practice A

Find the measures of the interior angles.

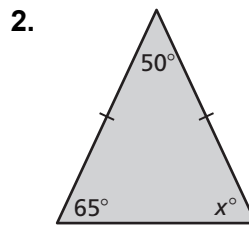

Find the measure of the exterior angle.

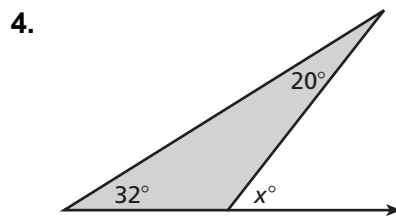
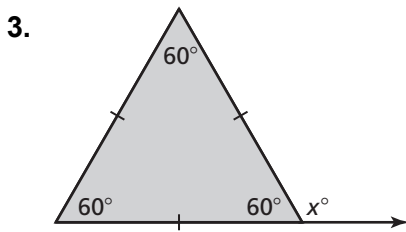

Tell whether a triangle can have the given angle measures. If not, change the first angle measure so that the angle measures form a triangle.

5.  $36.9^\circ, 110.4^\circ, 33.7^\circ$       6.  $62^\circ, 44\frac{3}{4}^\circ, 73\frac{1}{4}^\circ$

7. Consider the three isosceles right triangles.

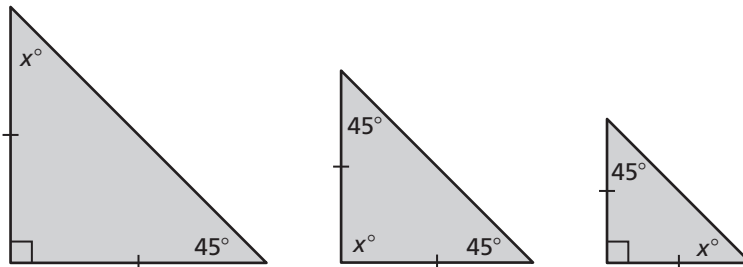

- Find the value of  $x$  for each triangle.
- What do you notice about the interior angle measures of each triangle?
- Write a rule about the interior angle measures of an isosceles right triangle.

## 3.2 Practice B

Find the measures of the interior angles.

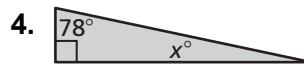
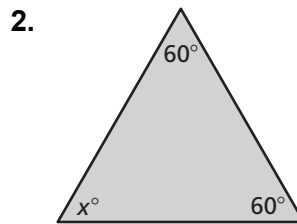
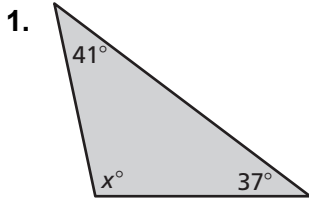

Find the measure of the exterior angle.

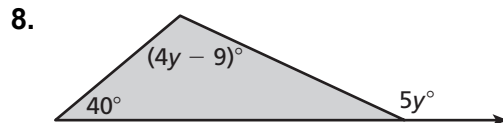
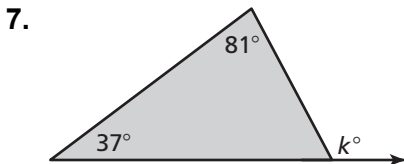
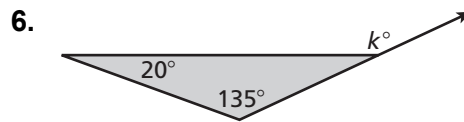
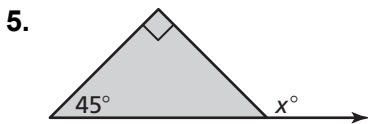

9. The ratio of the interior angle measures of a triangle is  $1 : 4 : 5$ . What are the angle measures?
10. A right triangle has a exterior angles with a measure of  $160^\circ$ . Can you determine the measures of the interior angles? Explain.

# 3.2

## Enrichment and Extension

### Writing Ratios

The sides of a right triangle can be named by their location with respect to an angle of the triangle.

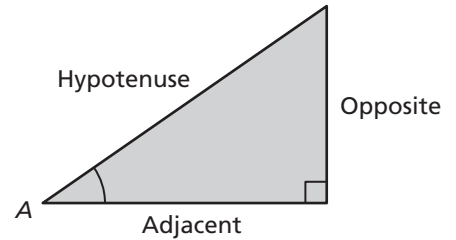

### Trigonometry

It is possible to write ratios that compare the lengths of the sides in the triangle using special functions and a given angle. These ratios are called sine (sin), cosine (cos), and tangent (tan) and are studied in depth in a branch of mathematics called trigonometry.

$$\sin A = \frac{\text{Opposite}}{\text{Hypotenuse}} \quad \cos A = \frac{\text{Adjacent}}{\text{Hypotenuse}} \quad \tan A = \frac{\text{Opposite}}{\text{Adjacent}}$$

Write the ratios. Use your answers and the color key to shade the mosaic.

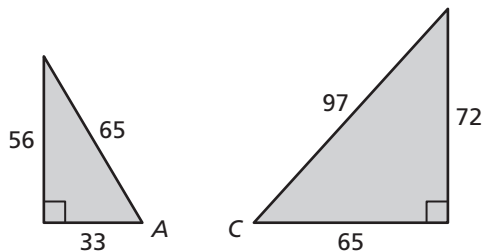

1.  $\sin A$
2.  $\tan C$
3.  $\cos A$
4.  $\tan A$
5.  $\sin C$
6.  $\cos C$

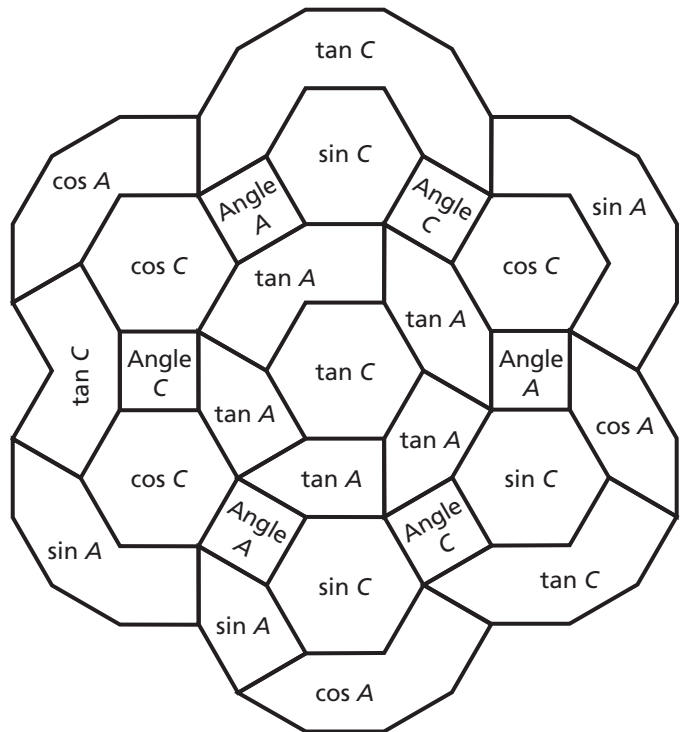

**Key:**  
 Angles = Blue  
 65 in the denominator = Red  
 97 in the denominator = Yellow  
 33 in the denominator = Purple



## Puzzle Time

### Did You Hear The Story About The Piece Of Butter?

A	B	C	D	E	F
G	H	I			

Complete each exercise. Find the answer in the answer column. Write the word under the answer in the box containing the exercise letter.

88° DON'T
144° TOAST
122° TO
53° NEVER
90° JELLY
45° IT

Find the value of  $x$ .

A.

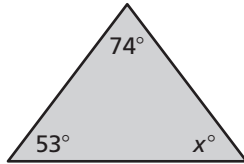

B.

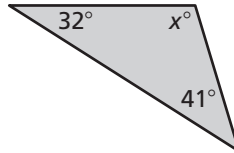

C.

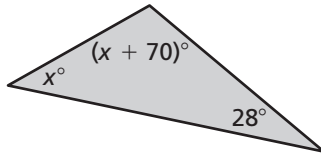

D.

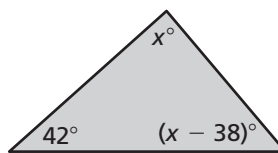

E. A triangle contains angles measuring  $25^\circ$  and  $75^\circ$ . What is the measure of the third angle?

Find the measure of the exterior angle.

F.

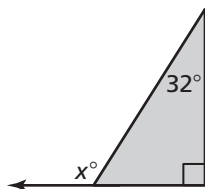

G.

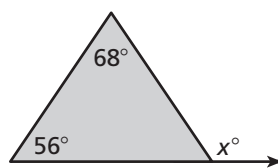

H.

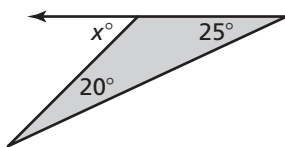

I.

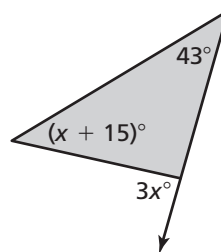

107° MIND
124° SPREAD
60° WHEAT
87° AROUND
41° I
80° WANT

**Activity****3.3****Start Thinking!**

For use before Activity 3.3

Many road signs are polygons. Try to come up with as many different road signs as you can. For each sign, classify the polygon by the number of sides.

**Activity****3.3****Warm Up**

For use before Activity 3.3

**Find the value of  $y$  for the given value of  $x$ .**

1.  $y = \frac{1}{2}x - 3; x = -2$

2.  $y = -x + 2; x = 15$

3.  $y = 10(x - 2); x = 10$

4.  $y = 13(x - 3); x = 1$

5.  $y = \frac{3}{2}x + \frac{5}{2}; x = -2$

6.  $y = 3(x + 4); x = -5$



**Lesson**  
**3.3**

**Start Thinking!**

For use before Lesson 3.3

Explain how you can draw an octagon on graph paper to make it easy to find the angle measures. Use this method to find each angle measure.

What is the sum of the angle measures?

**Lesson**  
**3.3**

**Warm Up**

For use before Lesson 3.3

Use triangles to find the sum of the interior angle measures of the polygon.

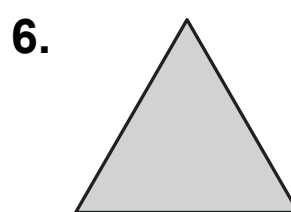
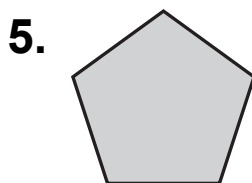
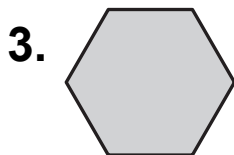
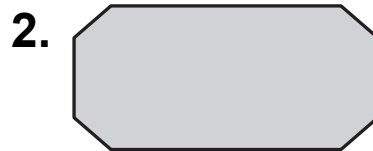
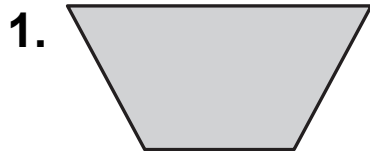

# 3.3

## Practice A

Use triangles to find the sum of the interior angle measures of the polygon.

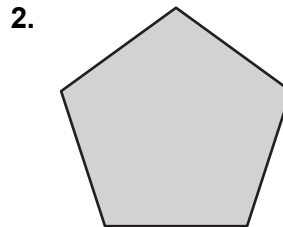
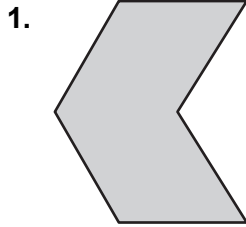

Find the sum of the interior angle measures of the polygon.

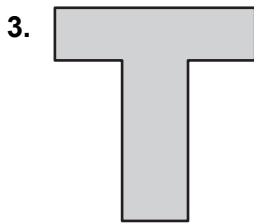

5. Can an octagon have interior angles that measure  $100^\circ$ ,  $156^\circ$ ,  $125^\circ$ ,  $90^\circ$ ,  $175^\circ$ ,  $134^\circ$ ,  $160^\circ$ , and  $140^\circ$ ? Explain.

Find the measures of the interior angles.

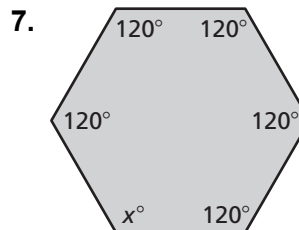
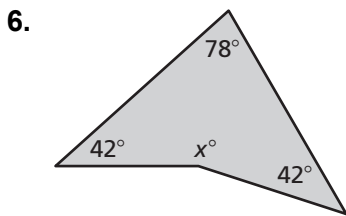

8. A stop sign is in the shape of a regular octagon. What is the measure of each interior angle?

Find the measures of the exterior angles of the polygon.

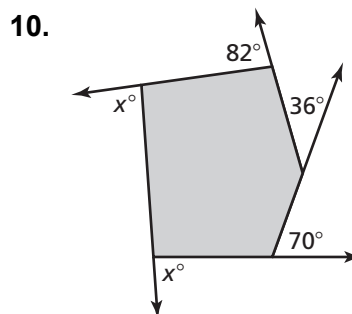
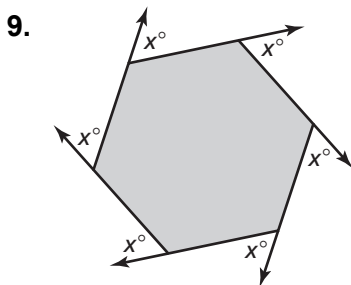

# 3.3

## Practice B

Use triangles to find the sum of the interior angle measures of the polygon.

1.

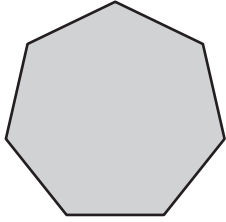

2.

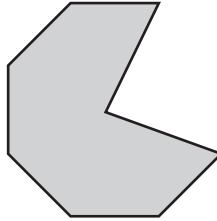

Find the sum of the interior angle measures of the polygon.

3.

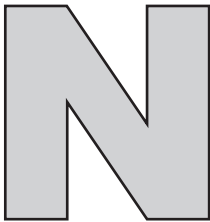

4.

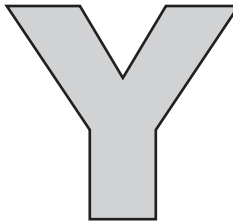

5. Four interior angles of a pentagon measure  $50^\circ$ ,  $73^\circ$ ,  $146^\circ$ , and  $161^\circ$ . Find the missing angle measure.

Find the measures of the interior angles.

6.

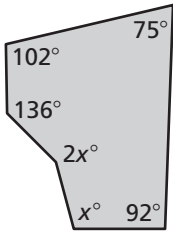

7.

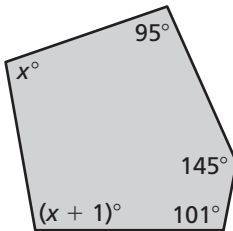

8. The interior angles of a regular polygon each measure  $135^\circ$ . How many sides does the polygon have?

9. Use the polygon shown.

- Is the polygon *convex* or *concave*?
- Is the polygon *regular* or *not regular*?
- What is the name of the polygon?
- What is the sum of the interior angle measures in the polygon?

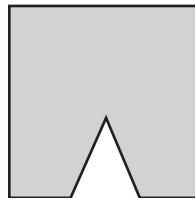

## 3.3

# Enrichment and Extension

### Area of Regular Polygons

To find the area of a regular polygon with more than four sides, you need to know the length of the *apothem*. The apothem is the distance from the center to any side of the polygon.

Once you know the length of the apothem, you can calculate the area of a regular polygon using

the formula  $A = \frac{1}{2}ans$ , where  $a$  is the length of

the apothem,  $n$  is the number of sides in the polygon, and  $s$  is the length of the sides.

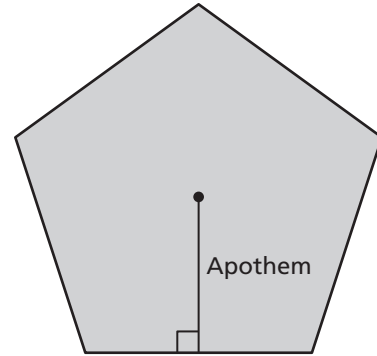

**Find the area of the regular polygon.**

1.

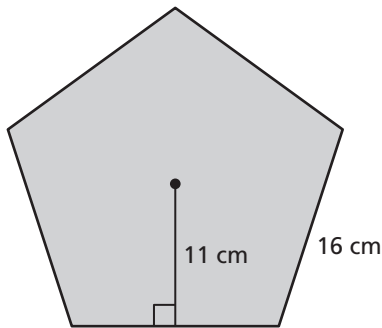

2.

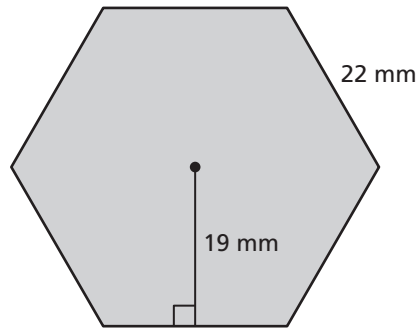

3.

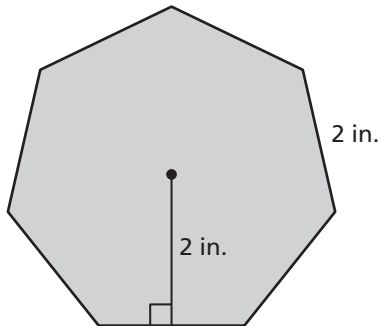

4.

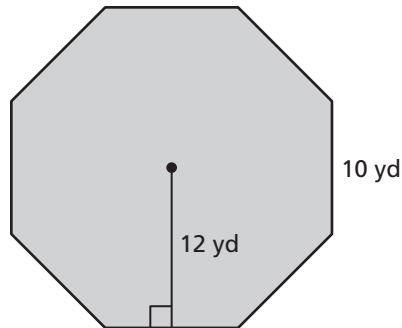



### Puzzle Time

## Why Did Old Mother Hubbard Scream When She Went To Fetch Her Poor Dog A Bone?

A	B	C	D	E	F
G	H				

Complete each exercise. Find the answer in the answer column. Write the word under the answer in the box containing the exercise letter.

720° GOT
135° WAS
124 THE
convex SHE

Tell whether the polygon is *convex* or *concave*.

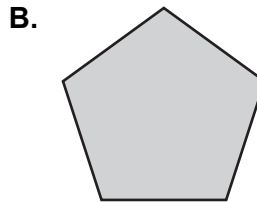
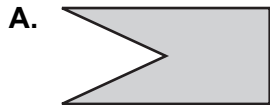

concave WHEN
15 CUPBOARD
1080° THERE
60° BEAR

Find the sum of the interior angle measures of the polygon.

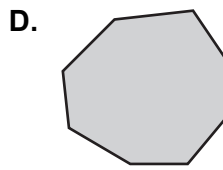
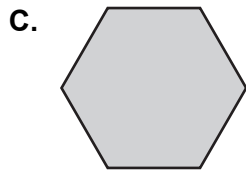

Find the value of  $x$ .

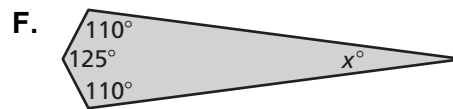
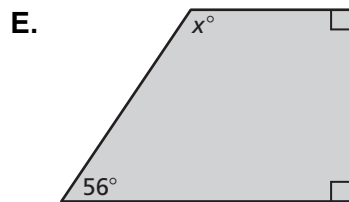

Find the measure of each interior angle of the regular polygon.

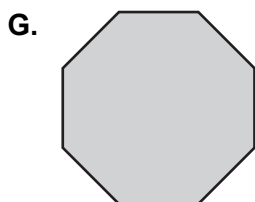

**Activity**  
**3.4**

**Start Thinking!**

For use before Activity 3.4

Which pairs of shapes appear to be *similar*?  
How can you tell?

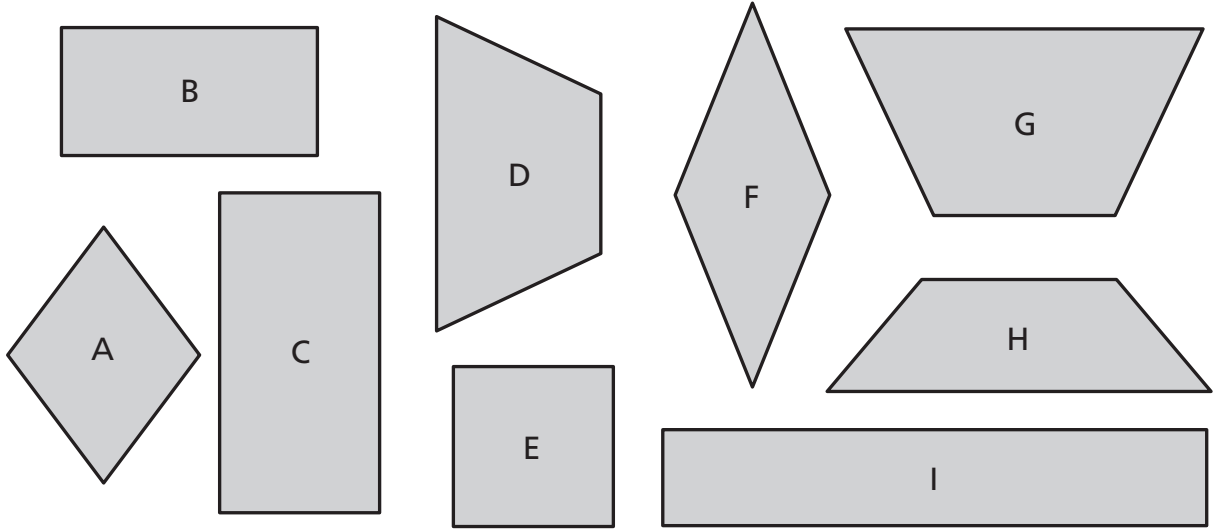

**Activity**  
**3.4**

**Warm Up**

For use before Activity 3.4

The triangles are similar. Find the value of  $x$ .

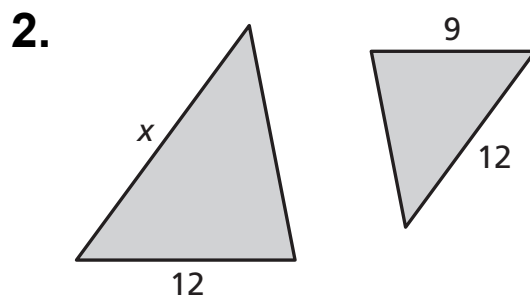
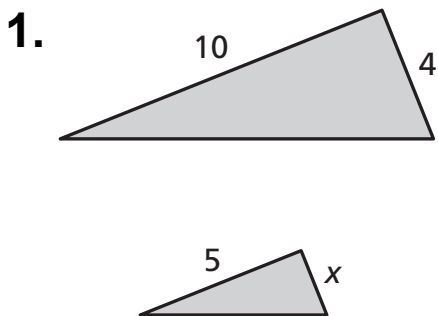

**Lesson**  
**3.4**

**Start Thinking!**

For use before Lesson 3.4

Thales was a Greek philosopher and mathematician who lived around 600 B.C. There are several accounts of how he used indirect measurement to find the height of the Great Pyramid in Giza.

According to one account, when his shadow was the same length as his height, he measured the length of the Great Pyramid's shadow.

What does this have to do with similar triangles?

**Lesson**  
**3.4**

**Warm Up**

For use before Lesson 3.4

**Make a triangle that is larger or smaller than the one given and has the same angle measures. Find the ratios of the corresponding side lengths.**

1.

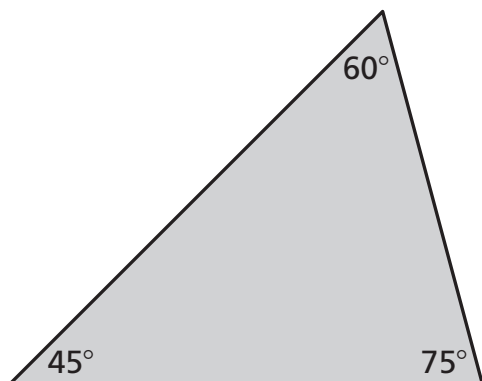

2.

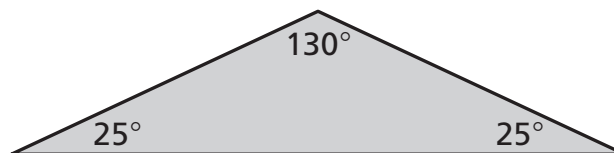

# 3.4

## Practice A

Tell whether the triangles are similar. Explain.

1.

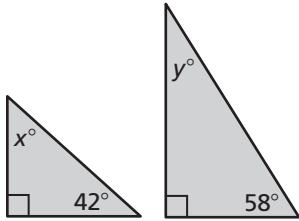

2.

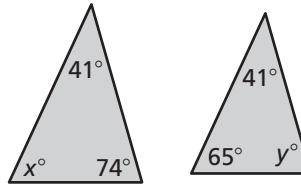

3. The triangles are similar. Find the value of  $x$ .

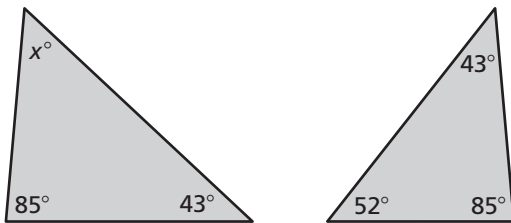

4. You can use indirect measurement to estimate the height of a building. First measure your distance from the base of the building and the distance from the ground to a point on the building that you are looking at. Maintaining the same angle of sight, move back until the top of the building is in your line of sight.

- Explain why  $\triangle ABC$  and  $\triangle DBE$  are similar.
- What is the height of the building?

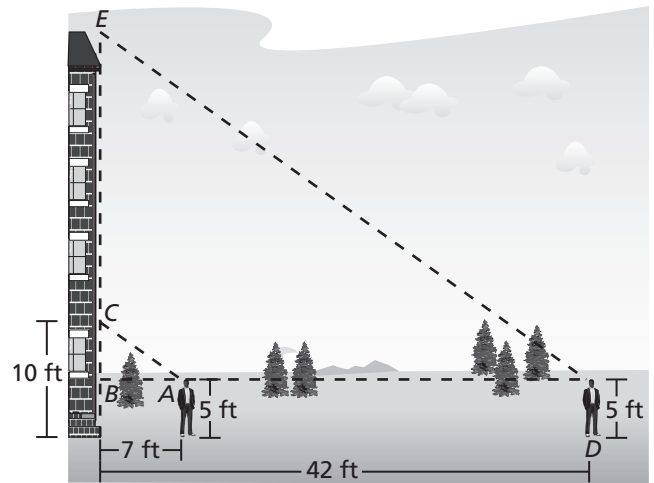

5. You and your friend are practicing for a rowing competition and want to know how far it is to an island in the Indian River Lagoon. You take measurements on your side of the lagoon and make the drawing shown.

- Explain why  $\triangle ABC$  and  $\triangle DEC$  are similar.
- What is the distance to the island?

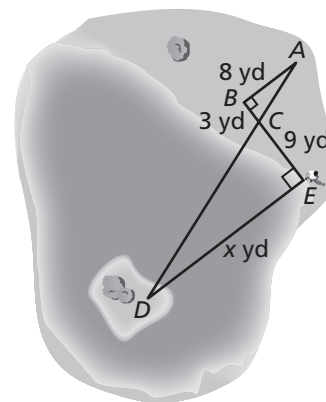



# 3.4

## Practice B

Tell whether the triangles are similar. Explain.

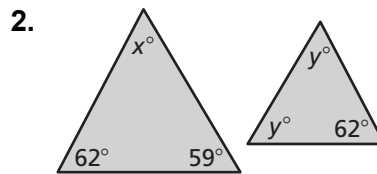
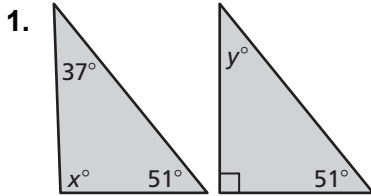

3. The triangles are similar. Find the value of  $x$ .



4. You can use indirect measurement to estimate the height of a flag pole. First measure your distance from the base of the flag pole and the distance from the ground to a point on the flag pole that you are looking at. Maintaining the same angle of sight, move back until the top of the flag pole is in your line of sight.

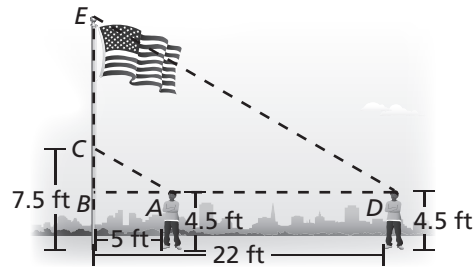

- a. Explain why  $\triangle ABC$  and  $\triangle DBE$  are similar.
- b. What is the height of the flag pole?

5. You are on a boat in the ocean, at Point  $A$ . You locate a lighthouse at Point  $D$ , beyond the line of sight of the marker at point  $C$ . You drive 0.2 mile west to Point  $B$  and then 0.1 mile south to Point  $C$ . You drive 0.3 mile more to arrive at Point  $E$ , which is due east of the lighthouse.

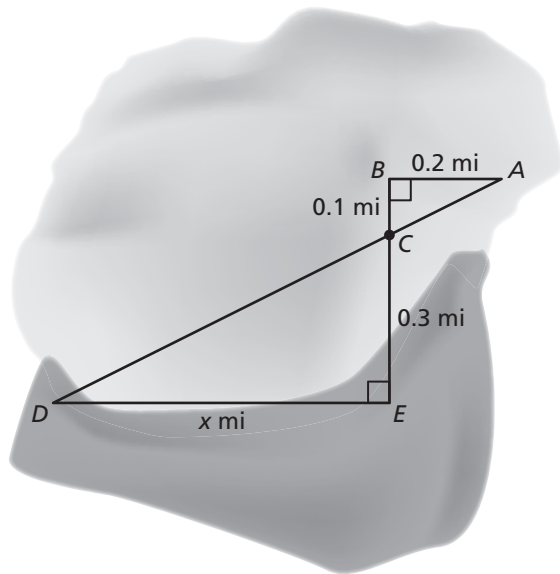

- a. Explain why  $\triangle ABC$  and  $\triangle DEC$  are similar.
- b. What is the distance from Point  $E$  to the lighthouse?

## 3.4 Enrichment and Extension

### Tessellations

A *tessellation* is a collection of figures that covers a plane with no gaps or overlaps. A *semi-regular tessellation* is a pattern formed by using two or more regular polygons.

Use the tessellation to answer the questions.

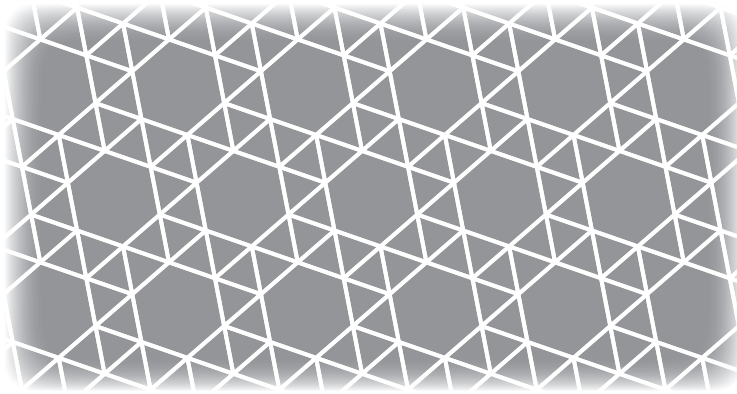

1. Is the tessellation semi-regular? How do you know?
2. Identify the two regular polygons used in the tessellation.
3. What is the measure of one angle of the triangle used in the tessellation?
4. What is the measure of one angle of the hexagon used in the tessellation?
5. A vertex is the point at which several polygons come together. Identify and mark one vertex in the tessellation.
6. Traveling clockwise, name the polygons that meet at your vertex.
7. What is the sum of the angles that meet at the vertex?
8. Give two examples where tessellations are used in real life.
9. Name the polygons that are found in your real-life examples from Exercise 8.

# 3.4 Puzzle Time

## What Do You Call A Dandelion Floating In The Ocean?

Write the letter of each answer in the box containing the exercise number.

Choose the correct letter that describes the triangles.

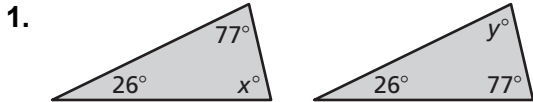

- A. similar      B. not similar

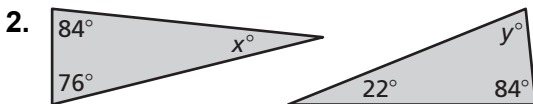

- C. similar      D. not similar



- E. similar      F. not similar

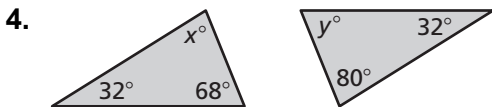

- G. similar      H. not similar

**Answers**

R. B

A. D

T. H

E. 58

D. A

M. E

S. G

E. 18

W. 70

N. C

E. F

The triangles are similar. Find the value of x.

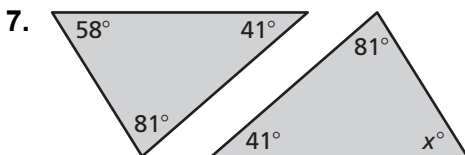
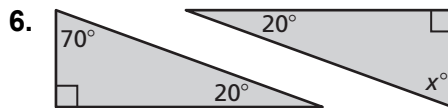
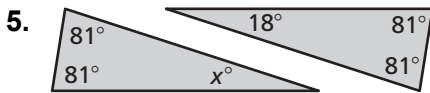

4	7	2		6	5	3	1
---	---	---	--	---	---	---	---

**Chapter**  
**3**
**Technology Connection**

For use after Section 3.3

**Exploring Tessellations**

In Section 3.3, you learned that a *tessellation* is a covering (or tiling) of a surface with one or more geometric shapes so that there are no gaps or overlaps. Many computer software programs have the capability to produce tessellations; however, the process is much simpler if the program has the ability to draw regular polygons, maintain the polygon's shape when resizing, copy and paste, and color each shape in the drawing.

**EXAMPLE** Use a computer drawing program to create a tessellation of regular hexagons.

**SOLUTION**

**Step 1** Use the Insert menu (or similar) to find and insert a graphic of a regular hexagon. When inserting or resizing the hexagon, usually holding the Shift key will keep the shape regular.

**Step 2** After resizing your hexagon to your desired size, use the copy and paste commands to populate your screen with hexagons.

**Step 3** Finish the tessellation by formatting the hexagons with a pattern of different colors.

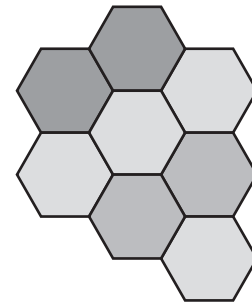

**Use a computer program to produce tessellations of the following figures.**

- regular hexagons and equilateral triangles

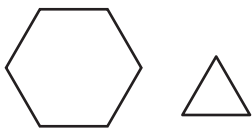

- squares and equilateral triangles

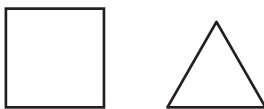

- regular hexagons, squares, and equilateral triangles

