

Chapter 2

Family and Community Involvement (English).....	43
Family and Community Involvement (Spanish)	44
Section 2.1	45
Section 2.2	51
Section 2.3	57
Section 2.4	63
Section 2.5	69
Section 2.6	75
Technology Connection.....	81

**Chapter
2**
Fractions and Decimals

Dear Family,

Many of us have a number of recipes that we enjoy preparing. Perhaps they are old family recipes or simply someone's favorite meal. Some recipes we can prepare without much effort: a quarter cup of butter, a quarter cup of flour, and two cups of milk for a white sauce.

However, when we have guests over for dinner, we find these familiar recipes have to be adjusted. Maybe we have to make three times as many servings. Now we need three quarter cups of butter, three quarter cups of flour, and so on.

Sometimes we want to make a smaller portion, such as when part of the family is away. Now we find ourselves using half a quarter cup of butter, half a quarter cup of flour, and so on.

You and your student can discuss strategies for preparing a meal when you have to change the recipe. For example, you might ask your student:

- "We have to use two quarter cups of sugar. Should we use the $\frac{1}{4}$ cup measure twice, or use the $\frac{1}{2}$ cup measure?" Your student may answer, "The amount will be the same either way."
- "The recipe calls for $\frac{2}{3}$ cup of milk, but we only want a half batch. What measuring cup should we use?" Your student may answer, "Use the $\frac{1}{3}$ cup measure, but only once."
- "Grandma's brownie muffin recipe makes enough for three dozen muffins, but we only want one dozen. What should we do?" Your student may answer, "We can divide the recipe measures by three."

Sometimes you have to make a judgment call. How do you cut the recipe in half, if it calls for three eggs? Talk with your student about different strategies for changing a recipe like this.

Enjoy your cooking time together!

Homemade Macaroni & Cheese

$\frac{1}{4}$ c butter	$2 \frac{1}{2}$ c grated cheese
$\frac{1}{4}$ c flour	$\frac{1}{2}$ 16 oz box of macaroni
2 c milk	salt & pepper

Make the macaroni using instructions on the box. Make a roux of the butter and flour. Add the milk over low heat while stirring until smooth. Add cheese to thickened sauce. Salt & pepper to taste. Stir in macaroni and serve.

Capítulo 2

Fracciones y decimales

Estimada Familia:

Muchos de nosotros tenemos una serie de recetas que disfrutamos preparar. Tal vez son antiguas recetas de la familia o simplemente la comida favorita de alguien. Algunas recetas las preparamos sin mucho esfuerzo: un cuarto de taza de mantequilla, un cuarto de taza de harina y dos tazas de leche para una salsa blanca. Sin embargo, cuando tenemos invitados a cenar, tenemos que adaptar estas recetas familiares. Quizás tenemos que preparar el triple de porciones. Ahora necesitaremos tres cuartos de taza de mantequilla, tres cuartos de taza de harina, etc.

A veces queremos hacer una porción más pequeña, cuando por ejemplo, parte de la familia no se encuentra en casa. Entonces tendremos que usar medio cuarto de taza de mantequilla, medio cuarto de taza de harina, etc.

Usted y su estudiante pueden conversar acerca de las estrategias que hay que usar para preparar una comida cuando tiene que cambiar la receta. Por ejemplo, puede preguntar a su estudiante:

- "Tenemos que usar dos cuartos de taza de azúcar. ¿Usamos dos veces la medida de $\frac{1}{4}$ de taza, o usamos la medida de $\frac{1}{2}$ taza?" Su estudiante puede responder: "La cantidad será igual de cualquier manera."
- "La receta indica $\frac{2}{3}$ de taza de leche, pero sólo queremos tener la mitad de la hornada. ¿Qué taza de medir debemos usar?" Su estudiante puede responder: "Usemos la medida de $\frac{1}{3}$ de taza, pero sólo una vez."
- "La receta de brownie muffins de la abuela rinde tres docenas de muffins, pero sólo queremos una docena. ¿Qué hacemos?" Su estudiante puede responder: "Podemos dividir las medidas de la receta entre tres."

A veces tenemos que tomar nuestra propia decisión. ¿Cómo dividir una receta en la mitad, si ésta incluye tres huevos? Converse con su estudiante acerca de estrategias diferentes para cambiar una receta como ésta.

¡Disfruten su momento de cocina juntos!

Macarrones con Queso Preparados en Casa

1/4 taza de mantequilla	2 1/2 tazas de queso rallado
1/4 taza de harina	1/2 caja de macarrones de
2 tazas de leche	16 onzas
sal y pimienta	

Prepare los macarrones siguiendo las instrucciones de la caja. Haga una salsa con la mantequilla y la harina. Vierta la leche a fuego lento y revuelva hasta que quede suave. Agregue el queso a la salsa espesa. Ponga sal y pimienta al gusto. Vierta los macarrones, revuelva y sirva.

**Activity
2.1****Start Thinking!**

For use before Activity 2.1

One of the games on a television game show involves rolling a ten-sided die, labeled with whole numbers 1 through 10. Each contestant rolls the die twice. The first roll gives the numerator of a fraction. The second roll gives the denominator.

Fraction: $\frac{\bigcirc}{\bigcirc}$

What would you hope to roll on each roll if you want to create the fraction with the greatest value? with the least value? Explain.

**Activity
2.1****Warm Up**

For use before Activity 2.1

Write the fraction in simplest form.

1. $\frac{6}{48}$

2. $\frac{9}{36}$

3. $\frac{6}{9}$

4. $\frac{12}{27}$

5. $\frac{16}{38}$

6. $\frac{18}{21}$

**Lesson
2.1****Start Thinking!**

For use before Lesson 2.1

The product of what two fractions is represented by the shaded region in the diagram below?

What is the product? How do you know?

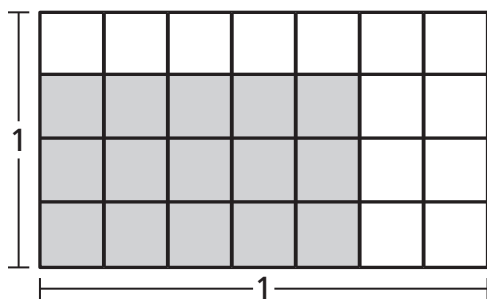
**Lesson
2.1****Warm Up**

For use before Lesson 2.1

Multiply. Write the answer in simplest form.

1. $\frac{2}{9} \times \frac{3}{5}$

2. $\frac{4}{5} \times \frac{3}{8}$

3. $\frac{1}{3} \times \frac{2}{3}$

4. $\frac{7}{12} \times \frac{1}{14}$

5. $\frac{4}{9} \times \frac{2}{3}$

6. $\frac{4}{11} \times \frac{1}{2}$

2.1 Practice A**Multiply. Write the answer in simplest form.**

1. $\frac{3}{5} \times \frac{1}{4}$

2. $\frac{1}{3} \times \frac{4}{7}$

3. $\frac{2}{3} \times \frac{7}{11}$

4. $\frac{6}{7} \times \frac{5}{6}$

5. $\frac{2}{5} \times \frac{5}{8}$

6. $\frac{8}{15} \times \frac{3}{10}$

7. $\frac{2}{9} \times \frac{12}{13}$

8. $\frac{7}{8} \times 12$

9. $4 \times \frac{5}{12}$

10. $\frac{4}{9} \times \frac{4}{9}$

11. $\frac{3}{14} \times \frac{7}{9}$

12. $\frac{8}{9} \times \frac{24}{11}$

13. $2\frac{2}{5} \times \frac{1}{4}$

14. $5\frac{3}{5} \times \frac{5}{7}$

15. $5\frac{1}{2} \times \frac{7}{11}$

16. $6\frac{2}{3} \times 12$

17. $4\frac{2}{5} \times 1\frac{7}{8}$

18. $9 \times 2\frac{2}{3}$

19. $4\frac{4}{9} \times \frac{3}{8}$

20. $3\frac{5}{8} \times 12$

21. $4\frac{2}{3} \times \frac{3}{14}$

22. Describe and correct the error in finding the product.

$$\times \quad 3\frac{7}{8} \times 6\frac{2}{5} = 18\frac{14}{40} = 18\frac{7}{20}$$

23. Two-fifths of the students in your class are in the band. Of these, one-fourth play the saxophone.

a. What fraction of your class plays the saxophone?

b. There are 30 students in your class. How many students in your class play the saxophone?

24. Five years ago, an alligator was $2\frac{1}{6}$ feet long. Today, the alligator is three times longer. How long is the alligator now?

25. A poster is $8\frac{1}{2}$ inches by 11 inches. You enlarge the poster by increasing each dimension by a factor of $2\frac{1}{2}$. What is the area of the new poster?

2.1 Practice B

Multiply. Write the answer in simplest form.

1. $\frac{1}{6} \times \frac{5}{9}$

2. $\frac{2}{5} \times \frac{7}{8}$

3. $\frac{6}{7} \times \frac{2}{9}$

4. $18 \times \frac{5}{6}$

5. $\frac{5}{24} \times \frac{8}{15}$

6. $\frac{16}{7} \times \frac{21}{8}$

7. Describe and correct the error in finding the product.

$$\times \frac{5}{6} \times \frac{5}{6} = \frac{5 \times 5}{6} = \frac{25}{6} = 4\frac{1}{6}$$

8. One-half of your CDs are scratched. Of those, one-fifth will not play properly. You have 40 CDs. How many of them will not play properly?

Multiply. Write the answer in simplest form.

9. $2\frac{11}{12} \times \frac{2}{5}$

10. $1\frac{3}{4} \times \frac{20}{21}$

11. $4\frac{9}{10} \times 1\frac{1}{7}$

12. $28 \times 8\frac{2}{7}$

13. $5\frac{5}{12} \times 2\frac{2}{5}$

14. $8\frac{1}{3} \times 4\frac{1}{2}$

15. Find the area of the shaded region. Explain how you found the area.

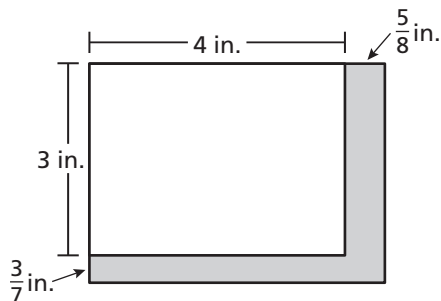

Multiply. Write the answer in simplest form.

16. $\frac{1}{4} \times \frac{5}{8} \times \frac{16}{25}$

17. $\left(\frac{2}{7}\right)^3$

18. $\left(\frac{5}{7}\right)^2 \times \left(\frac{3}{5}\right)^2$

19. $\frac{3}{5} \times 6\frac{3}{4} \times 2\frac{2}{9}$

20. $1\frac{7}{8} \times 12 \times 3\frac{2}{3}$

21. $4\frac{1}{6} \times 2\frac{2}{7} \times 7\frac{1}{5}$

2.1

Enrichment and Extension

Using Fractions

Use fractions to solve each problem. Write the answer in simplest form.

1. After each round of a basketball tournament, half of the teams are eliminated. The tournament began with 64 teams.
 - a. How many teams are left after the third round?
 - b. How many rounds will have been completed after the championship game?

2. A deposit of \$1000 is made in a savings account. After one year, the new balance is $\frac{11}{10}$ the value of the original deposit.
 - a. Write a product that can be used to find the new balance in the account.
 - b. After the second year, the balance is $\frac{6}{5}$ the value of the account balance after the first year. Find the balance after the second year.

You make painting designs for your ceiling. You will paint the shaded region. Find the area of the shaded region in the design.

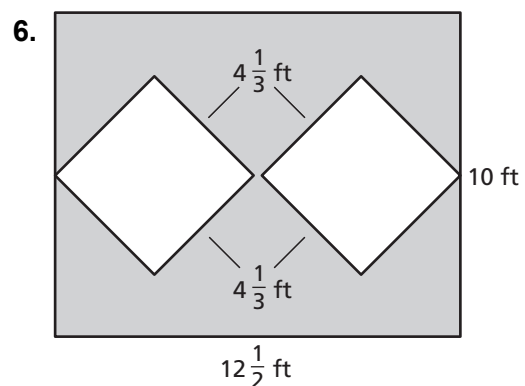
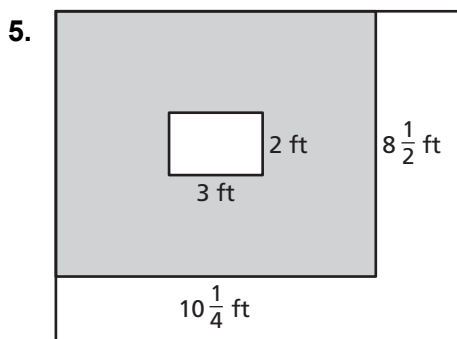
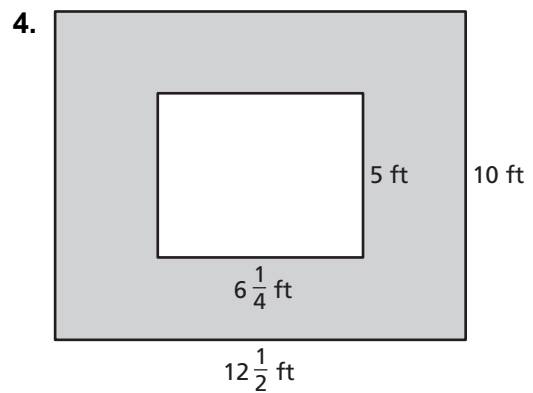
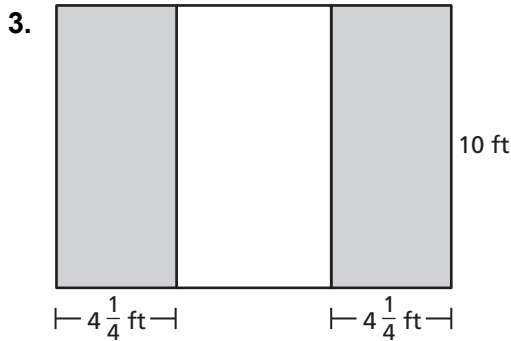



Puzzle Time

Why Did The Turkey Volunteer To Be The Drummer In The Popular Bird Band?

Write the letter of each answer in the box containing the exercise number.

Multiply. Write the answer in simplest form.

1. $\frac{1}{8} \times \frac{3}{5}$

2. $\frac{1}{6} \times \frac{3}{8}$

3. $\frac{3}{4} \times \frac{9}{13}$

4. $\frac{5}{6} \times \frac{6}{7}$

5. $\frac{5}{16} \times \frac{1}{10}$

6. $\frac{3}{14} \times 12$

7. $8 \times \frac{9}{10}$

8. $\frac{5}{7} \times \frac{5}{8}$

9. $\frac{14}{15} \times \frac{5}{7}$

10. $1\frac{1}{4} \times \frac{3}{4}$

11. $7\frac{1}{2} \times \frac{4}{5}$

12. $\frac{5}{8} \times 1\frac{3}{5}$

13. $6\frac{1}{4} \times \frac{2}{5}$

14. $2\frac{7}{10} \times \frac{5}{9}$

15. $\frac{2}{9} \times 3\frac{1}{6}$

16. $1\frac{5}{7} \times 21$

17. $4\frac{3}{8} \times 2\frac{2}{7}$

18. $\frac{1}{8} \times \frac{3}{5} \times \frac{2}{3}$

19. $\frac{6}{7} \bullet \frac{6}{7}$

20. $\left(\frac{2}{5}\right)^2$

21. $\left(\frac{3}{4}\right)^2 \bullet \frac{1}{3}$

22. The photo of you and your friends at the local amusement park has a length of $5\frac{1}{3}$ inches and a width of $3\frac{1}{4}$ inches. Find the area in square inches of the photo of you and your friends.

Answers for 1-22.

S. $7\frac{1}{5}$

C. $\frac{27}{52}$

A. $\frac{3}{40}$

E. $\frac{19}{27}$

Y. $\frac{2}{3}$

D. $2\frac{1}{2}$

H. $\frac{1}{16}$

U. 36

L. $\frac{1}{20}$

D. $1\frac{1}{2}$

A. $\frac{4}{25}$

D. $\frac{1}{32}$

E. $\frac{3}{16}$

R. $\frac{15}{16}$

R. 1

T. 6

K. $\frac{36}{49}$

I. 10

A. $2\frac{4}{7}$

M. $\frac{5}{7}$

H. $\frac{25}{56}$

S. $17\frac{1}{3}$

2	15		6	18	10	21	1	13	9		8	20	5		14	12	16	4	22	11	17	3	19	7
---	----	--	---	----	----	----	---	----	---	--	---	----	---	--	----	----	----	---	----	----	----	---	----	---

Activity
2.2**Start Thinking!**

For use before Activity 2.2

The recommended serving size listed on a box of cereal is $\frac{3}{4}$ cup.

You also know the amount of cereal left in the box. What can you find out using these two pieces of information? How?

Activity
2.2**Warm Up**

For use before Activity 2.2

Find the product. Write the answer in simplest form.

1. $\frac{1}{8} \times \frac{2}{5}$

2. $\frac{4}{7} \times \frac{5}{16}$

3. $\frac{1}{3} \times \frac{1}{8}$

4. $4 \times \frac{3}{16}$

5. $15 \times \frac{2}{3}$

6. $9 \times \frac{4}{15}$

**Lesson
2.2****Start Thinking!**

For use before Lesson 2.2

Come up with an easy way to remember how to find the reciprocal of a fraction.

**Lesson
2.2****Warm Up**

For use before Lesson 2.2

Divide. Write the answer in simplest form.

1. $\frac{2}{5} \div \frac{1}{8}$

2. $\frac{4}{7} \div \frac{4}{23}$

3. $\frac{1}{3} \div \frac{1}{8}$

4. $4 \div \frac{3}{16}$

5. $\frac{2}{3} \div 8$

6. $\frac{4}{15} \div \frac{1}{9}$

2.2 Practice A

Write the reciprocal of the number.

1. $\frac{5}{8}$

2. 6

3. $\frac{1}{3}$

4. $\frac{7}{4}$

Divide. Write the answer in simplest form.

5. $\frac{1}{6} \div \frac{1}{3}$

6. $\frac{3}{4} \div 6$

7. $\frac{3}{5} \div \frac{2}{15}$

8. $10 \div \frac{2}{7}$

9. $\frac{3}{8} \div \frac{9}{16}$

10. $\frac{5}{9} \div 15$

11. $\frac{10}{27} \div \frac{2}{3}$

12. $\frac{18}{25} \div \frac{8}{15}$

13. $\frac{7}{12} \div 14$

14. Describe and correct the error in finding the quotient.

$$\times \quad \frac{3}{4} \div 6 = \frac{3}{4} \div \frac{6}{1} = \frac{18}{4} = \frac{9}{2} = 4\frac{1}{2}$$

Determine whether the numbers are reciprocals. If not, write the reciprocal of each number.

15. $\frac{5}{8}, \frac{16}{10}$

16. $\frac{1}{12}, 12$

17. $\frac{2}{3}, \frac{12}{18}$

18. $\frac{4}{7}, \frac{7}{8}$

Copy and complete the statement.

19. $\frac{10}{7} \times \underline{\quad ? \quad} = 1$

20. $8 \div \underline{\quad ? \quad} = 24$

21. You have $\frac{2}{3}$ of a pizza. You divide the remaining pizza into 4 equal pieces.

What fraction of the pizza is each piece?

22. You have five quarts of paint. It takes $\frac{5}{8}$ quart to paint each chair you are asked to paint. How many chairs can you paint?

23. Is the reciprocal of a fraction always a whole number? Explain.

2.2 Practice B

Write the reciprocal of the number.

1. $\frac{7}{12}$

2. $\frac{1}{10}$

3. 15

4. $\frac{21}{5}$

Divide. Write the answer in simplest form.

5. $\frac{3}{8} \div \frac{15}{16}$

6. $9 \div \frac{6}{5}$

7. $\frac{2}{3} \div \frac{2}{9}$

8. $\frac{4}{15} \div 12$

9. $\frac{3}{7} \div \frac{9}{14}$

10. $\frac{8}{15} \div 20$

11. $\frac{3}{4} \div \frac{7}{12}$

12. $18 \div \frac{4}{7}$

13. $\frac{16}{25} \div \frac{3}{5}$

14. Describe and correct the error in finding the quotient.

$$\times \frac{3}{5} \div \frac{9}{10} = \frac{5}{3} \cdot \frac{10}{9} = \frac{50}{27} = 1\frac{23}{27}$$

Without finding the quotient, copy and complete the statement using $<$, $>$, or $=$. Explain your reasoning.

15. $4 \div \frac{6}{7} \underline{\quad ? \quad} 4$

16. $1 \div \frac{2}{3} \underline{\quad ? \quad} 1$

17. $\frac{4}{5} \div \frac{9}{10} \underline{\quad ? \quad} \frac{4}{5}$

Evaluate the expression. Write the answer in simplest form.

18. $\frac{1}{5} \div 5 \div 3$

19. $8 \div \frac{4}{5} + \frac{7}{9}$

20. $\frac{11}{24} \cdot \left(\frac{5}{16} \div \frac{5}{12} \right)$

21. How many times larger is a 10-pound dog than a hamster weighing $\frac{5}{8}$ pound?

22. A digital camera memory card is $\frac{1}{4}$ full. The card is $\frac{2}{3}$ full when 375 more pictures have been taken.

a. How many pictures can the memory card hold?

b. How many pictures were originally on the memory card?

2.2 Enrichment and Extension

Finding a Combination

9, 9

2, 7

3, 5

4, 6

1, 4

5, 7

3, 6

3, 8

You keep money in a locked box and do not want to write the combination down to open the box. So, you create the problems below and numbers above to hide the combination. Choose a set of numbers and fill in the boxes to make each equation true. Each set of numbers will be used once.

$$1. \frac{\square}{2} \div \frac{3}{8} = \frac{\square}{3}$$

$$2. \frac{\square}{4} \div 2 = \frac{\square}{8}$$

$$3. \frac{\square}{2} \div \frac{1}{4} = \square$$

$$4. \frac{5}{14} \div \frac{2}{\square} = \frac{\square}{4}$$

$$5. \frac{1}{\square} \div \frac{3}{8} = \frac{1}{\square}$$

$$6. \frac{7}{2} \div \square = \frac{1}{\square}$$

$$7. \frac{5}{9} \div \frac{2}{\square} = \frac{\square}{6}$$

$$8. \frac{1}{\square} \div \frac{3}{2} = \frac{1}{\square}$$

9. Starting at Exercise 1 and ending at Exercise 8, write down each number that was missing from the right side of the equation. Place a dash after every second digit. This series of two digit numbers will unlock the box. What is the combination to the box?

2.2 Puzzle Time

Why Was The Gentleman Who Was Selling Watches Unhappy?

Write the letter of each answer in the box containing the exercise number.

Write the reciprocal of the number.

1. 5 2. 12 3. $\frac{2}{3}$
 4. $\frac{4}{9}$ 5. $\frac{7}{6}$ 6. $\frac{1}{8}$

Divide. Write the answer in simplest form.

7. $\frac{1}{16} \div \frac{1}{8}$ 8. $\frac{6}{7} \div \frac{3}{5}$ 9. $14 \div \frac{2}{7}$
 10. $\frac{5}{8} \div 10$ 11. $\frac{14}{15} \div 7$ 12. $\frac{5}{24} \div \frac{5}{6}$
 13. $\frac{9}{20} \div \frac{3}{4}$ 14. $\frac{1}{4} \div \frac{1}{36}$ 15. $\frac{7}{8} \div 28$
 16. $3 \div \frac{2}{3}$ 17. $\frac{3}{14} \div \frac{9}{11}$ 18. $18 \div \frac{9}{13}$
 19. $\frac{1}{9} \div 9 \div 9$ 20. $3 \div \frac{9}{11} + \frac{1}{3}$ 21. $\frac{1}{2} + \frac{7}{8} \div \frac{11}{24}$
 22. $\frac{5}{12} \times \frac{2}{3} \div \frac{2}{9}$ 23. $\frac{8}{21} \div \frac{2}{3} \times \frac{4}{9}$ 24. $\frac{9}{16} \div 18 \div 8$

25. There are 3 pieces of pizza left. How many $\frac{1}{4}$ pieces of pizza can be sliced from the 3 pieces of pizza?

Answers for 1–6.

A. $\frac{6}{7}$ M. $\frac{9}{4}$ H. $\frac{1}{5}$
 O. 8 N. $\frac{3}{2}$ S. $\frac{1}{12}$

Answers for 7–25.

A. $\frac{11}{42}$ N. $4\frac{1}{2}$ I. 49
 O. $\frac{2}{15}$ H. $\frac{1}{2}$ L. 26
 S. 9 I. $\frac{3}{5}$ D. $\frac{1}{16}$
 F. $1\frac{3}{7}$ T. $\frac{1}{32}$ H. $\frac{1}{4}$
 O. 12 H. $2\frac{9}{22}$ E. $\frac{1}{256}$
 A. $1\frac{1}{4}$ E. $\frac{1}{729}$ T. 4
 D. $\frac{16}{63}$

12	24		1	22	10		17		18	25	15		11	8		20	9	4	19	
6	16		21	13	2		7	5	3	23	14									

Activity
2.3**Start Thinking!**

For use before Activity 2.3

Amber says that $8 \div 1\frac{3}{4}$ is the same as $8 \times 1\frac{4}{3}$.

Is she correct? How do you know?

Activity
2.3**Warm Up**

For use before Activity 2.3

Write the improper fraction as a mixed number.

1. $\frac{12}{5}$

2. $\frac{21}{4}$

3. $\frac{16}{9}$

4. $\frac{27}{6}$

5. $\frac{80}{3}$

6. $\frac{55}{9}$

**Lesson
2.3****Start Thinking!**

For use before Lesson 2.3

A beaded necklace has broken and the beads have fallen all over the floor. The diameter of each bead is $1\frac{1}{4}$ centimeters. Using the string

from the broken necklace, how can you find out how many beads were on the necklace without counting them?

**Lesson
2.3****Warm Up**

For use before Lesson 2.3

Divide. Write the answer in simplest form.

1. $1\frac{2}{5} \div \frac{1}{2}$

2. $3\frac{1}{2} \div \frac{2}{5}$

3. $2\frac{1}{7} \div \frac{3}{7}$

4. $5\frac{1}{3} \div 2\frac{1}{4}$

5. $1\frac{5}{12} \div 2\frac{1}{10}$

6. $9\frac{1}{6} \div 2\frac{1}{5}$

2.3 Practice A

Divide. Write the answer in simplest form.

1. $2\frac{1}{2} \div \frac{1}{4}$

2. $4\frac{1}{3} \div \frac{2}{3}$

3. $6\frac{2}{3} \div \frac{5}{6}$

4. $8\frac{1}{3} \div 2\frac{2}{9}$

5. $9\frac{4}{5} \div 7$

6. $3\frac{5}{9} \div 16$

7. $\frac{8}{27} \div 4\frac{2}{9}$

8. $21 \div 5\frac{1}{4}$

9. $9\frac{3}{5} \div 12$

10. $3\frac{3}{4} \div 5\frac{1}{4}$

11. $7\frac{1}{2} \div 1\frac{3}{4}$

12. $6\frac{2}{9} \div 6\frac{2}{3}$

13. Describe and correct the error in finding the quotient.

$$\times \quad 8 \div 2\frac{3}{4} = \frac{1}{8} \div \frac{11}{4} = \frac{1}{8} \times \frac{4}{11} = \frac{1}{22}$$

Evaluate the expression. Write the answer in simplest form.

14. $3\frac{3}{8} \div 4\frac{7}{8} + 3$

15. $4\frac{1}{2} - \frac{3}{4} \div 2\frac{3}{8}$

16. $3\frac{3}{5} - \frac{1}{2} \div 4\frac{3}{8}$

17. $\frac{2}{3} \times \frac{5}{8} \div 3\frac{7}{12}$

18. How many $6\frac{1}{4}$ -inch pieces of fabric can be cut from a 75-inch roll?

19. How many times heavier is a $16\frac{1}{2}$ -pound rock than a $10\frac{1}{2}$ -pound rock?

20. How many $2\frac{1}{2}$ -acre plots can be made out of a 35-acre field?

21. A bag contains 36 cups of flour. How many loaves of bread can be made if each loaf takes $5\frac{1}{3}$ cups? Is there any flour left over? If so, how much?

2.3 Practice B

Divide. Write the answer in simplest form.

1. $3\frac{1}{2} \div 2\frac{1}{4}$

2. $7\frac{3}{4} \div 1\frac{5}{8}$

3. $4\frac{1}{2} \div 2\frac{2}{3}$

4. $10 \div 2\frac{2}{9}$

5. $16\frac{1}{3} \div 14$

6. $8\frac{2}{5} \div \frac{9}{10}$

7. $\frac{3}{4} \div 8\frac{1}{4}$

8. $6\frac{1}{2} \div 3\frac{3}{4}$

9. $18 \div 4\frac{1}{5}$

10. $\frac{7}{16} \div 5\frac{1}{4}$

11. $10\frac{2}{3} \div 3\frac{1}{5}$

12. $9\frac{4}{9} \div 5\frac{2}{3}$

13. Describe and correct the error in finding the quotient.

$$\times \quad 8\frac{1}{3} \div 15 = \frac{25}{3} \div 15 = 15 \times \frac{3}{25} = \frac{45}{25} = \frac{9}{5} = 1\frac{4}{5}$$

Evaluate the expression. Write the answer in simplest form.

14. $4\frac{1}{5} \div 2\frac{1}{10} - \frac{1}{2}$

15. $10\frac{1}{8} \div 3\frac{1}{8} + \frac{4}{5}$

16. $2\frac{1}{6} \div 3 + 5\frac{1}{2}$

17. $4\frac{3}{8} \div \frac{5}{16} \times \frac{3}{4}$

18. $2\frac{3}{7} \div \frac{2}{3} \times \frac{3}{4}$

19. $5\frac{1}{3} + 2\frac{7}{12} \div \frac{3}{4}$

20. $9\frac{1}{3} \times 4\frac{1}{2} + 3\frac{2}{5}$

21. $4\frac{1}{9} \times 3\frac{2}{3} \div 1\frac{2}{9}$

22. $6\frac{3}{4} \div \left(2\frac{3}{5} \times 1\frac{2}{13}\right)$

23. How many $3\frac{3}{4}$ -inch wires can be cut from a spool of wire that is 100 inches long? Will there be any wire left over? If so, how much?

24. A bag of fertilizer that weighs $18\frac{3}{4}$ pounds can cover 5000 square feet. How many pounds of fertilizer will be needed to cover 27,000 square feet? How many bags of fertilizer are needed? Explain how you found your answer.

2.3 Enrichment and Extension

Tic-Tac-Toe

Copy the value descriptions below on pieces of paper and place them in a hat. Choose one description from the hat. Then find the expression on the board whose value matches the description. Put an "X" in the box above that expression. Choose another description and put an "O" above its matching expression. Keep alternating between X and O until the board is full. Get three Xs or three Os in a row horizontally, vertically, or diagonally to win. Did the Xs or Os win?

Do not put the descriptions back in the hat after you have chosen them.

<div style="border: 1px solid black; width: 60px; height: 60px; margin: 0 auto;"></div> $2\frac{11}{12} \div \frac{7}{9} \times 3\frac{1}{20}$	<div style="border: 1px solid black; width: 60px; height: 60px; margin: 0 auto;"></div> $10\frac{1}{2} \div 4\frac{5}{7} \div \frac{10}{11}$	<div style="border: 1px solid black; width: 60px; height: 60px; margin: 0 auto;"></div> $4\frac{2}{5} \times 3\frac{3}{10} \div 2\frac{14}{15}$
<div style="border: 1px solid black; width: 60px; height: 60px; margin: 0 auto;"></div> $15\frac{3}{4} \div 2\frac{9}{20} + 1\frac{11}{28}$	<div style="border: 1px solid black; width: 60px; height: 60px; margin: 0 auto;"></div> $28\frac{1}{8} \div 6\frac{3}{7} \div 4\frac{13}{20}$	<div style="border: 1px solid black; width: 60px; height: 60px; margin: 0 auto;"></div> $6\frac{12}{13} - 6\frac{9}{10} \div 1\frac{4}{35}$
<div style="border: 1px solid black; width: 60px; height: 60px; margin: 0 auto;"></div> $8\frac{1}{6} \div 1\frac{2}{5} - 1\frac{1}{6}$	<div style="border: 1px solid black; width: 60px; height: 60px; margin: 0 auto;"></div> $12\frac{3}{4} + 5\frac{5}{8} \div 4\frac{1}{14}$	<div style="border: 1px solid black; width: 60px; height: 60px; margin: 0 auto;"></div> $7\frac{3}{11} \div \frac{5}{22} \div 3\frac{5}{17}$

• The value is about $2\frac{1}{2}$.

• The value is about $9\frac{1}{2}$.

• The value is more than 14.

• The value is about $\frac{1}{2}$.

• The value is between 7 and 8.

• The value is about $11\frac{1}{2}$.

• The value is about 1.

• The value is equivalent to $4\frac{95}{100}$.

• The value is between $4\frac{1}{2}$ and $4\frac{3}{4}$.

2.3 Puzzle Time

What Does An Ant Use To Keep All Of Its Hair In Place?

Write the letter of each answer in the box containing the exercise number.

Divide. Write the answer in simplest form.

1. $1\frac{3}{5} \div \frac{4}{5}$

2. $5\frac{1}{4} \div \frac{3}{4}$

3. $12\frac{2}{5} \div \frac{1}{5}$

4. $2\frac{2}{3} \div 2\frac{2}{3}$

5. $7\frac{1}{7} \div \frac{10}{11}$

6. $3\frac{1}{6} \div \frac{5}{6}$

7. $\frac{7}{9} \div 2\frac{13}{18}$

8. $12\frac{1}{2} \div 15$

9. $14 \div 9\frac{1}{3}$

10. $5\frac{1}{8} \div 6\frac{5}{6}$

11. $3\frac{5}{8} \div 5\frac{4}{5}$

12. $16 \div 4\frac{2}{3}$

13. $4\frac{1}{4} \div \frac{1}{8}$

14. $17 \div 2\frac{4}{15} + 2\frac{5}{12}$

15. $1\frac{3}{7} \div \frac{5}{6} \div 4\frac{4}{5}$

16. $2\frac{5}{8} \div 1\frac{5}{9} \times 1\frac{1}{9}$

17. $2\frac{3}{11} + \frac{4}{9} \div 1\frac{7}{15}$

Answers

E. $1\frac{7}{8}$

A. $3\frac{3}{7}$

G. 1

D. $1\frac{1}{2}$

H. 2

P. $\frac{2}{7}$

R. 34

X. $\frac{5}{8}$

U. $7\frac{6}{7}$

Y. 7

A. $9\frac{11}{12}$

O. $2\frac{19}{33}$

T. $\frac{5}{6}$

B. $\frac{3}{4}$

L. 62

S. $3\frac{4}{5}$

R. $\frac{5}{14}$

16	11	8	13	14		1	17	3	9		10	5	4		6	7	15	12	2
----	----	---	----	----	--	---	----	---	---	--	----	---	---	--	---	---	----	----	---

Activity
2.4**Start Thinking!**

For use before Activity 2.4

Make a list of ways you add and subtract decimals in real life.

Compare your list with a partner.

Activity
2.4**Warm Up**

For use before Activity 2.4

Add or subtract.

1. $25 + 17$

2. $48 + 32$

3. $102 + 59$

4. $38 - 26$

5. $64 - 37$

6. $121 - 53$

Lesson
2.4

Start Thinking!

For use before Lesson 2.4

You go shopping for school supplies. You buy 5 items that cost the following: \$0.75, \$2.49, \$3.97, \$1.97, and \$5.50.

You pay with a \$15 gift card. Is there any money left on the gift card? Explain to a partner how to find the answer.

Lesson
2.4

Warm Up

For use before Lesson 2.4

Write and evaluate the numerical expression modeled by the base ten blocks.

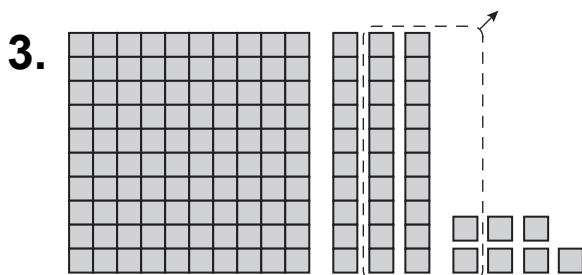
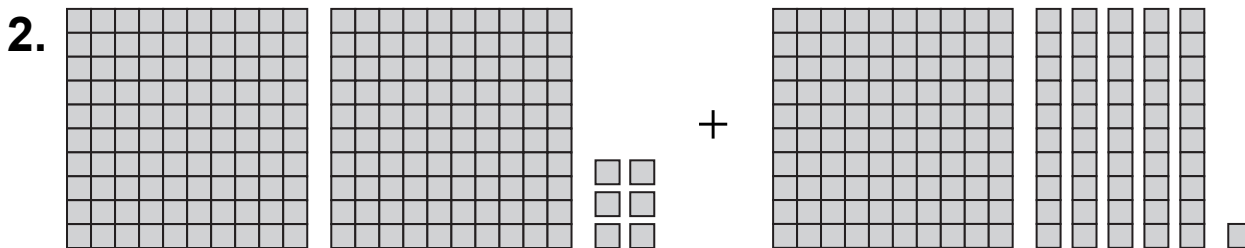
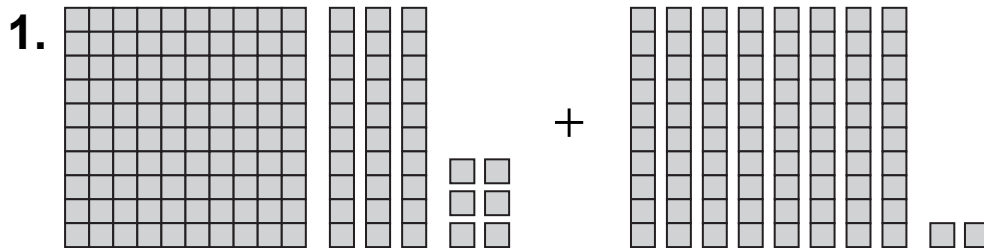

2.4 Practice A**Add.**

1. $6.58 + 2.436$

2. $1.8 + 4.307$

3. $11.415 + 15.32$

4. $16.75 + 14.349$

5. $18.741 + 14.113$

6. $12.799 + 17.301$

Subtract.

7. $5.64 - 2.31$

8. $9.385 - 5.216$

9. $9.75 - 6.523$

10. $16.435 - 12.144$

11. $18.908 - 14.76$

12. $10.8 - 8.752$

13. It costs \$5.52 to park in parking lot A and \$3.75 to park in parking lot B. How much more does it cost to park in parking lot A?

Evaluate the expression.

14. $7.85 + 12.19 + 5.401$

15. $9.112 + 7.649 - 11.52$

16. $16.072 - 13.18 + 3.982$

17. $18.2 - 14.33 + 9.757$

18. $17.816 - 8.623 - 5.94$

19. $6.58 + 7.64 - 10.006$

20. Write two decimals that have a sum of 16.825.

21. Write two decimals that have a difference of 16.825.

22. To find the girth of a suitcase, add the length, width, and depth.

- a. Your suitcase has a length of 24.5 inches, a width of 14.25 inches, and a depth of 6.875 inches. Find the girth of your suitcase.
- b. In order to store your suitcase in the overhead compartment, the girth must not exceed 45 inches. Will you be able to store your suitcase in the overhead compartment? Explain.

23. You are saving money for a new bicycle, which costs \$85.99. So far you have saved \$47.52. How much more money do you need before you can purchase the new bicycle?

24. A triangle has sides of length 15.463 centimeters, 11.34 centimeters, and 20.875 centimeters. What is the perimeter of the triangle?

2.4 Practice B**Add.**

1. $9.241 + 3.64$ 2. $6.72 + 9.8$ 3. $14.068 + 12.337$
4. $21.389 + 10.852$ 5. $17.004 + 24.987$ 6. $16.556 + 17.618$

Subtract.

7. $8.79 - 2.53$ 8. $7.328 - 6.54$ 9. $12.026 - 7.51$
10. $20.75 - 11.132$ 11. $21.708 - 18.768$ 12. $24.53 - 21.952$

13. The large bottle of nasal spray is 9.46 centimeters tall. The small bottle is 5.29 centimeters tall. How much shorter is the small bottle than the large bottle?

Evaluate the expression.

14. $8.42 + 10.43 + 8.507$ 15. $25.46 - 13.49 + 5.647$
16. $9.245 + 14.52 - 17.423$ 17. $20.497 - 4.52 - 8.779$
18. $26.742 + 15.146 - 8.074$ 19. $24.699 - 12.524 - 8.67$

20. The table shows the dimensions, in inches, of two picture frames that are in the shape of right triangles.

a. How much larger is the hypotenuse of Frame A than Frame B?

	Leg 1	Leg 2	Hypotenuse
Frame A	3	6.2	6.888
Frame B	4.2	5.1	6.607

b. What is the perimeter of Frame A?

c. What is the perimeter of Frame B?

d. What is the sum of the two perimeters?

e. Find the sum of the two legs of each picture frame. Which frame has the larger sum of two legs?

21. At Station M, the price of gas is \$3.319 per gallon and the price of diesel is \$4.429 per gallon. You buy 2 gallons of gas and your friend buys 2 gallons of diesel. How much more did your friend pay?

2.4

Enrichment and Extension

Perimeter

In Exercises 1–4, find the perimeter of the figure.

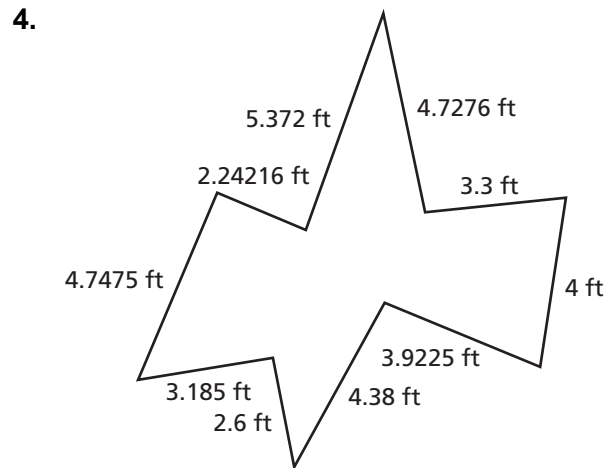
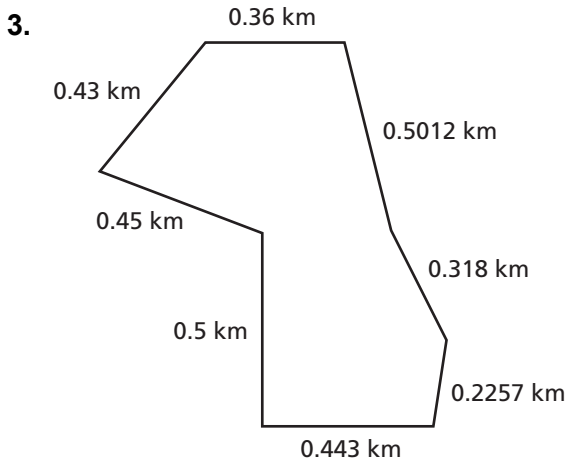
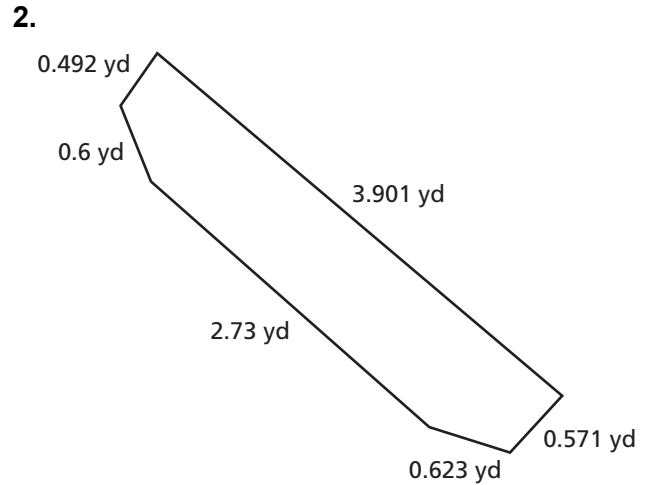
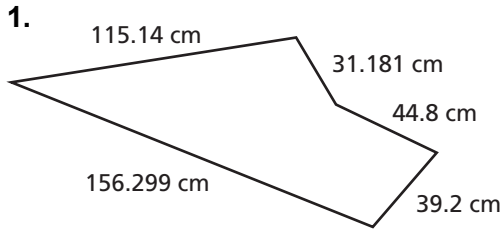

5. In Exercise 1, the side of the figure that is 156.299 centimeters decreased to 103.1 centimeters.
 - a. How can you find the new perimeter using subtraction?
 - b. What is the new perimeter?
6. The figure in Exercise 3 is being used to construct a new city zoo. The perimeter will be enclosed with fencing. How much fencing, in meters, will be needed to enclose the zoo property? (Hint: 1000 meters = 1 kilometer)

2.4 Puzzle Time

Did You Hear About...

A	B	C	D	E	F
G	H	I	J	K	L
M	N	O	P	Q	

Complete each exercise. Find the answer in the answer column. Write the word under the answer in the box containing the exercise letter.

44.5 BEAK
11.524 ELECTRIC
3.31 A
4.883 HE
17.2 BULB
5.65 HAVE
6.485 BIRD
8.012 SWITCH
7.652 WATER
2.633 SO
11.11 POND
40.059 HIS

Add.

- A. $8.93 + 2.108$ B. $2.6 + 3.885$
 C. $23.938 + 9.06$ D. $19.46 + 12.657$
 E. $28.551 + 11.508$ F. $26.367 + 18.133$

Subtract.

- G. $5.69 - 4.23$ H. $7.518 - 4.208$
 I. $5.87 - 3.725$ J. $16.242 - 12.68$
 K. $24.6 - 21.967$ L. $26.73 - 21.847$

Evaluate the expression.

- M. $7.206 + 9.3 + 4.186$
 N. $23.7 - 13.397 - 4.653$
 O. $26.46 + 8.715 - 14.065$
 P. $17.6 - 14.56 + 8.484$
 Q. The rectangular sandbox at the local community park has a width of 24.5 meters and its length is 31.7 meters. What is the perimeter, in meters, of the rectangular sandbox?

32.998 WHO
20.692 COULD
41.691 BRIGHT
11.038 THE
112.4 BILL
2.145 LIGHT
21.11 AN
32.117 STUCK
3.562 SOCKET
1.46 INTO
43.21 DUCK
28.51 KILOWATT

Activity
2.5**Start Thinking!**

For use before Activity 2.5

Describe a real-life situation that involves multiplying a decimal by a whole number.

Activity
2.5**Warm Up**

For use before Activity 2.5

Find the sum.

1. $0.4 + 0.4 + 0.4$

2. $0.12 + 0.12 + 0.12$

3. $2.7 + 2.7 + 2.7$

4. $0.41 + 0.41 + 0.41$

5. $0.6 + 0.6 + 0.6 + 0.6$

6. $0.15 + 0.15 + 0.15 + 0.15$

**Lesson
2.5****Start Thinking!**

For use before Lesson 2.5

You can use a model to find the product of decimals.

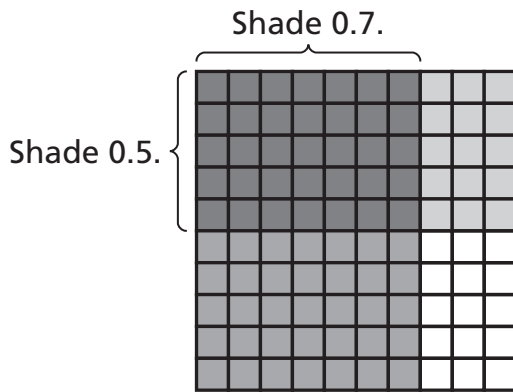

Explain why the model above shows that $0.5 \times 0.7 = 0.35$.

**Lesson
2.5****Warm Up**

For use before Lesson 2.5

Use base ten blocks or an area model to find the product.

1.
$$\begin{array}{r} 0.6 \\ \times 0.2 \\ \hline \end{array}$$

2.
$$\begin{array}{r} 2.3 \\ \times 1.7 \\ \hline \end{array}$$

3.
$$\begin{array}{r} 0.5 \\ \times 0.8 \\ \hline \end{array}$$

4.
$$\begin{array}{r} 1.6 \\ \times 0.7 \\ \hline \end{array}$$

5.
$$\begin{array}{r} 2.4 \\ \times 2.6 \\ \hline \end{array}$$

6.
$$\begin{array}{r} 2.1 \\ \times 0.7 \\ \hline \end{array}$$

2.5 Practice A

Copy the problem and place the decimal point in the product.

$$\begin{array}{r} 1. \quad 2.6 \\ \times 7.9 \\ \hline 2054 \end{array}$$

$$\begin{array}{r} 2. \quad 8.83 \\ \times 0.42 \\ \hline 37086 \end{array}$$

$$\begin{array}{r} 3. \quad 9.44 \\ \times 1.95 \\ \hline 184080 \end{array}$$

Multiply. Use estimation to check your answer.

4. 3.2×6

5. 5.1×8

6. 0.34×14

7. 8.4×3

8. 6.2×7

9. 1.3×3

10. 5.4×2.2

11. 6.13×15

12. 100×0.092

13. Describe and correct the error in the solution.

$\begin{array}{r} \times 0.0004 \\ \times 8 \\ \hline 0.032 \end{array}$
--

14. An international long-distance phone call costs \$0.79 per minute. How much will a 22-minute call cost?

Multiply.

15. $\begin{array}{r} 0.3 \\ \times 0.4 \\ \hline \end{array}$

16. $\begin{array}{r} 0.05 \\ \times 0.9 \\ \hline \end{array}$

17. $\begin{array}{r} 0.34 \\ \times 0.7 \\ \hline \end{array}$

18. 1.46×0.5

19. 19.4×4.8

20. 5.12×0.23

21. 2.024×1.35

22. 0.0032×16.4

23. 2.965×3.208

24. The area of Pennsylvania is 46,055 square miles. The area of Florida is about 1.428 times larger than Pennsylvania. What is the area of Florida to the nearest square mile?

25. You buy three baskets of fruit at \$5.65 per basket. You hand the cashier a \$20 bill. How much change will you get back?

2.5 Practice B

How many decimal places are in the product?

1. 2.37×0.8

2. 21.6×5.7

3. 6.25×0.25

Multiply.

4. 0.48×15

5. 7.4×5

6. 9.25×16

7. 2.84×21

8. 0.042×4

9. 0.035×7

10. 10×0.065

11. 18×0.012

12. 4×0.0137

13.
$$\begin{array}{r} 0.5 \\ \times 0.3 \\ \hline \end{array}$$

14.
$$\begin{array}{r} 0.49 \\ \times 0.8 \\ \hline \end{array}$$

15.
$$\begin{array}{r} 0.0015 \\ \times 0.004 \\ \hline \end{array}$$

16. 3.128×2.45

17. 100×0.0059

18. 3.659×3.126

19. The table shows the cost (in cents) of producing and distributing each coin for two years.

Coin	2000	2007
Quarter	4.38	9.78
Dime	1.92	4.09
Nickel	3.16	9.53
Penny	0.82	1.67

- a. Which coins cost less to make than they are worth?
Which coins cost more to make than they are worth?
- b. How much more does it cost to produce 50 of each coin in 2007 than in 2000?

20. A store is selling sculptures. The first week, it prices 6 sculptures at \$80 each. After each week, if a sculpture is not sold, it will be priced to sell for 0.85 times the previous week's price. The store needs to sell the 6 sculptures for a total of at least \$270 to make a profit. What is the last week in which all 6 sculptures could be sold so that the store makes a profit?
21. Which is greater, $7.8 \cdot (6.9 + 3.5)$ or $7.8 + (6.9 \cdot 3.5)$? Explain your answer.

Describe the pattern. Find the next three numbers.

22. 0.7, 2.1, 6.3, 18.9, ...

23. 0.13, 0.65, 3.25, 16.25, ...

24. 2, 0.04, 0.0008, 0.000016, ...

25. 6, 1.8, 0.54, 0.162, ...

2.5 Enrichment and Extension

Placing the Decimal Point

Coin	Thickness (mm)	Weight (oz)	Coins per Roll
Penny	1.55	0.088	50
Nickel	1.95	0.176	40
Dime	1.35	0.08	50
Quarter	1.75	0.2	40

In Exercises 1–4, use the table.

- How much taller is a roll of nickels than a roll of dimes?
- How much taller is a roll of pennies than a roll of quarters?
- You have 6 rolls of pennies and 4 rolls of quarters.
 - How much money do you have?
 - How much do the coins weigh?
- You have 1 roll of nickels, 4 rolls of dimes, and 2 rolls of quarters. Your friend has 3 rolls of pennies, 2 rolls of nickels, 1 roll of dimes, and 3 rolls of quarters.
 - Who has more money? By how much?
 - Whose coins weigh more? By how much?

Fill in the blanks and place a decimal point in the first factor to complete the statement.

$$\begin{array}{r}
 5. \quad \square 6 \\
 \times 9.\square \\
 \hline
 33\square \\
 5\square 4 \\
 \hline
 5\square.76
 \end{array}$$

$$\begin{array}{r}
 6. \quad 78\square \\
 \times \square.4 \\
 \hline
 312\square \\
 23\square 6 \\
 \hline
 26.\square 88
 \end{array}$$

$$\begin{array}{r}
 7. \quad 2\square 15 \\
 \times \square.3\square \\
 \hline
 846\square \\
 \square 345 \\
 \hline
 1\square 920 \\
 \hline
 17.6\square 910
 \end{array}$$

2.5 Puzzle Time

How Did The Goblin Football Player Score The Winning Touchdown?

Write the letter of each answer in the box containing the exercise number.

Multiply.

- | | |
|---|---|
| 1. 3.8×8 | 2. 5.1×8 |
| 3. 5.08×7 | 4. 2.24×3 |
| 5. 2.563×3 | 6. 0.024×8 |
| 7. 0.072×3 | 8. 0.0029×6 |
| 9. $\begin{array}{r} 0.8 \\ \times 0.3 \\ \hline \end{array}$ | 10. $\begin{array}{r} 0.07 \\ \times 0.2 \\ \hline \end{array}$ |
| 11. $\begin{array}{r} 0.006 \\ \times 0.04 \\ \hline \end{array}$ | 12. $\begin{array}{r} 0.0009 \\ \times 0.08 \\ \hline \end{array}$ |
| 13. $\begin{array}{r} 0.003 \\ \times 0.9 \\ \hline \end{array}$ | 14. $\begin{array}{r} 0.0007 \\ \times 0.005 \\ \hline \end{array}$ |
| 15. 2.25×4.46 | 16. 2.042×6.408 |

Evaluate the expression.

17. $3.1 \times 5 + 9$ 18. $8.2(2.3 + 1.7)$
19. $2^2 \times 3.3 + 7.645$ 20. $9.645 \times 3 \times 10$
21. A football weighs approximately 0.42 kilogram. The physical education teacher needs to purchase a dozen footballs. What will be the total weight, in kilograms, of the footballs to calculate shipping and handling?

Answers

O. 30.4	R. 0.24
N. 0.014	E. 0.00024
H. 0.000072	I. 0.0027
L. 289.35	H. 0.192
V. 0.0174	U. 5.04
O. 0.0000035	T. 32.8
E. 24.5	A. 20.845
G. 40.8	E. 0.216
H. 10.035	N. 35.56
R. 6.72	E. 7.689
L. 13.085136	

6	17		9	19	3		1	8	11	4		18	12	5		2	15	14	21	16		20	13	10	7
---	----	--	---	----	---	--	---	---	----	---	--	----	----	---	--	---	----	----	----	----	--	----	----	----	---

**Activity
2.6****Start Thinking!**

For use before Activity 2.6

How are multiplication and division related? Be sure to include examples in your explanation.

**Activity
2.6****Warm Up**

For use before Activity 2.6

Use base ten blocks to complete the statement.

1. 3 tenths = ? hundredths
2. 5 ones = ? tenths
3. 2 ones = ? hundredths
4. 20 hundredths = ? tenths
5. 37 hundredths = ? tenths and ? hundredths
6. 2 ones and 4 tenths = ? tenths

**Lesson
2.6****Start Thinking!**

For use before Lesson 2.6

List all of the ways that you can check your answer for a division problem.

**Lesson
2.6****Warm Up**

For use before Lesson 2.6

Use base ten blocks to find the quotient.

1. $7.2 \div 0.9$

2. $8.5 \div 0.5$

3. $0.81 \div 0.03$

4. $0.54 \div 0.06$

5. $20.7 \div 0.9$

6. $1.44 \div 0.12$

2.6 Practice A

Rewrite the problem so that the divisor is a whole number.

1. $4.2 \overline{)23.1}$

2. $0.15 \overline{)12.87}$

3. $0.535 \overline{)8.76}$

Divide. Use estimation to check your answer.

4. $7 \overline{)1.4}$

5. $5 \overline{)2.65}$

6. $6 \overline{)24.6}$

7. $21.6 \div 9$

8. $53.6 \div 8$

9. $0.256 \div 4$

10. Describe and correct the error in finding the quotient.

X	$ \begin{array}{r} 2.7 \\ 5 \overline{)1.35} \\ \underline{-10} \\ 35 \\ \underline{-35} \\ 0 \end{array} $
---	--

11. You and three of your friends go parasailing for \$128.40. You split the cost evenly. How much does each person pay?

Evaluate the expression.

12. $20.6 + 19.4 \div 2$

13. $23.43 \div 3 - 2.5$

14. $18.6 \div 3 \times 6$

15. $9.3 \div 3 + 7.6$

16. $48.02 \div 7 \div 2$

17. $17.5 \times (2.4 \div 3)$

Divide. Check your answer.

18. $0.5 \overline{)13.5}$

19. $2.5 \overline{)45.5}$

20. $5.6 \overline{)16.8}$

21. $8.82 \div 0.6$

22. $75 \div 2.5$

23. $4.08 \div 1.2$

24. $2.94 \div 0.21$

25. $90.2 \div 0.22$

26. $357 \div 0.007$

27. An MP3 player can hold 350 hours of music. Each song on an MP3 player is about 2.5 minutes in length. About how many songs can the MP3 player store?

28. A piece of paper is 0.0075 inch thick. How many sheets of paper will be in a stack that is 2.25 inches high?

Divide. Round to the nearest hundredth if necessary.

29. $25.6 \div 0.7$

30. $19.43 \div 0.003$

31. $56.22 \div 7.2$

2.6 Practice B

Divide. Use estimation to check your answer.

1. $9 \overline{)7.2}$

2. $6 \overline{)38.4}$

3. $5 \overline{)32.5}$

4. $1.08 \div 4$

5. $77.6 \div 8$

6. $60.2 \div 7$

7. $0.252 \div 9$

8. $42.66 \div 18$

9. $72.96 \div 16$

10. The table shows the ounces and costs of three boxes of the same cereal. Which box of cereal is the best buy? Explain.

Ounces	Cost
12	\$2.88
18	\$3.96
28	\$6.44

Evaluate the expression.

11. $23.4 + 34.4 \div 4$

12. $28.65 \div 5 - 4.85$

13. $21.5 \div 5 \times 8$

14. $7.3 \times 3.6 \div 9$

15. $79.8 \div 7 \div 3$

16. $18.1 \times (9.6 \div 6)$

Divide. Check your answer.

17. $1.4 \overline{)28.7}$

18. $0.25 \overline{)3.15}$

19. $6.3 \overline{)107.1}$

20. $10.16 \div 0.08$

21. $39.42 \div 7.2$

22. $75.25 \div 0.025$

23. $0.272 \div 0.016$

24. $78 \div 0.26$

25. $1.836 \div 0.0027$

26. You are saving your money to buy a guitar that costs \$275.75. You have \$40 and plan to save \$7.50 each week. Your uncle decides to give you an additional \$8 each week.

- How many weeks will you have to save until you have enough money to buy the guitar?
- How many more weeks would you have to save to buy a guitar that costs \$339.75? Explain how you found your answer.

Divide. Round to the nearest hundredth if necessary.

27. $30.48 \div 2.4$

28. $4.657 \div 0.35$

29. $60.258 \div 7.3$

Without finding the quotient, copy and complete the statement using $<$, $>$, or $=$.

30. $4.58 \div 0.57$? $45.8 \div 0.57$

31. $24.5 \div 0.4$? $24.5 \div 4$

2.6

Enrichment and Extension

Find the Missing Digit

Find the missing digit in the expression.

$$1. \begin{array}{r} 8.1 \\ \square 9 \overline{)396.9} \end{array}$$

R

$$2. \begin{array}{r} 3.5 \\ 21 \square \overline{)759.5} \end{array}$$

A

$$3. \begin{array}{r} 7.328 \\ \square 7 \overline{)710.816} \end{array}$$

H

$$4. \begin{array}{r} 6.42 \\ 1 \square \overline{)115.56} \end{array}$$

Y

$$5. \begin{array}{r} 0.407 \\ 5 \square 2 \overline{)224.664} \end{array}$$

T

$$6. \begin{array}{r} 2.01 \\ 7 \square 6 \overline{)1459.26} \end{array}$$

B

$$7. \begin{array}{r} 9.56 \\ 10 \square 1 \overline{)9856.36} \end{array}$$

E

$$8. \begin{array}{r} 37.14 \\ 2 \square \overline{)779.94} \end{array}$$

N

$$9. \begin{array}{r} 0.048 \\ 3 \square 75 \overline{)176.4} \end{array}$$

P

Use the values of the digits from Exercises 1–9 to find the answer to the riddle.

10. *I have a head and a tail, but no body. What am I?*

$\frac{\quad}{7} \quad \frac{\quad}{6} \quad \frac{\quad}{3} \quad \frac{\quad}{1} \quad \frac{\quad}{1} \quad \frac{\quad}{8}$

11. *I am light as a feather, but no one can hold me for long. What am I?*

$\frac{\quad}{7} \quad \frac{\quad}{2} \quad \frac{\quad}{4} \quad \frac{\quad}{3} \quad \frac{\quad}{7} \quad \frac{\quad}{5} \quad \frac{\quad}{9}$

Find the height of the figure.

12. $A = 12 \text{ m}^2$



4.8 m

13. $A = 11.0625 \text{ m}^2$



3.75 m

2.6 Puzzle Time

Why Did The Young Lady Go Buzz Buzz In The Hallway?

Write the letter of each answer in the box containing the exercise number.

Divide.

1. $5 \overline{)39.5}$

2. $8 \overline{)33.6}$

3. $17 \overline{)19.618}$

4. $12 \overline{)52.8}$

5. $45.87 \div 6$

6. $51.288 \div 4$

7. $15.75 \div 18$

8. $3.2 \div 0.4$

9. $0.07 \overline{)0.84}$

10. $3.2 \overline{)41.6}$

11. $4.9 \overline{)68.6}$

12. $0.5 \overline{)17.7}$

13. $50.56 \div 0.8$

14. $22.4 \div 0.04$

15. $33.6 \div 0.3$

16. $0.861 \div 0.7$

17. The perimeter of each face of a Rubik's cube is 22.2 centimeters. What is the length of an edge of a Rubik's cube?

Answers	
T. 7.645	A. 12
S. 13	S. 7.9
E. 4.2	H. 12.822
E. 560	A. 1.23
T. 5.55	E. 14
S. 63.2	U. 1.154
E. 0.875	D. 112
N. 35.4	B. 8
W. 4.4	

13	6	11		4	16	1		9		8	2	14		10	17	3	15	7	12	5
----	---	----	--	---	----	---	--	---	--	---	---	----	--	----	----	---	----	---	----	---

Chapter 2 **Technology Connection**
For use after Section 2.3

Using a Calculator with Fractions and Mixed Numbers

A calculator can be used to perform calculations with fractions and mixed numbers. Keep the order of operations in mind when you enter the expression. You can enter a mixed number in two ways:

Write the mixed number as a whole number plus a fraction.

$$1\frac{2}{5} = (1 + 2 \div 5)$$

Calculator Keystrokes:
 $\boxed{(\boxed{1} \boxed{+} \boxed{2} \boxed{\div} \boxed{5} \boxed{)}}$

Write the mixed number as an improper fraction.

$$1\frac{2}{5} = \frac{5 \times 1 + 2}{5} = ((5 \times 1 + 2) \div 5)$$

Calculator Keystrokes:
 $\boxed{(\boxed{(\boxed{5} \boxed{\times} \boxed{1} \boxed{+} \boxed{2} \boxed{)} \boxed{\div} \boxed{5} \boxed{)}}$

- Use one of the methods above to write the calculator keystrokes for $3\frac{7}{12}$.
- Use one of the methods above to write the calculator keystrokes for $\frac{5}{6}$.
- Use your answers to Exercises 1 and 2 to write the calculator keystrokes for $3\frac{7}{12} \div \frac{5}{6}$. Then use a calculator to find $3\frac{7}{12} \div \frac{5}{6}$.

Evaluate the expression. Write the answer as it appears on your calculator.

4. $4\frac{1}{6} \div 1\frac{1}{3}$ 5. $4\frac{1}{3} \div 2\frac{8}{9}$ 6. $9\frac{4}{5} \div \frac{7}{10}$ 7. $2\frac{1}{4} \div \frac{5}{8}$

8. Kelly and Jamie each wrote the keystrokes for $6 \div \frac{2}{3}$. Will both students' keystrokes give the same answer? What is the correct answer? Why?

Kelly

$$\boxed{(\boxed{6} \boxed{\div} \boxed{(\boxed{2} \boxed{\div} \boxed{3} \boxed{)}}$$

Jamie

$$\boxed{(\boxed{6} \boxed{\div} \boxed{2} \boxed{\div} \boxed{3} \boxed{)}}$$

Evaluate the expression. Write the answer as it appears on your calculator.

9. $2\frac{1}{2} + 1\frac{4}{5} \div \frac{3}{5} - \frac{1}{4}$ 10. $12\frac{4}{7} \times 1\frac{8}{9} \div 2\frac{3}{7}$ 11. $10\frac{1}{2} \div 1\frac{1}{4} - 3\frac{1}{5}$